

Internal Dimensions		
Width	Depth	Height
812	712	1216
Weight	Approx. 37 Kg	
Wall Thickness		7mm

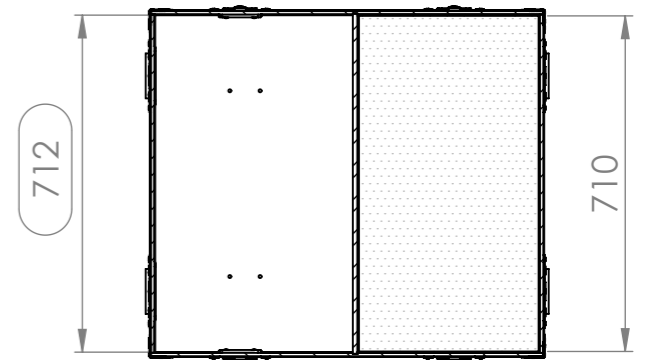
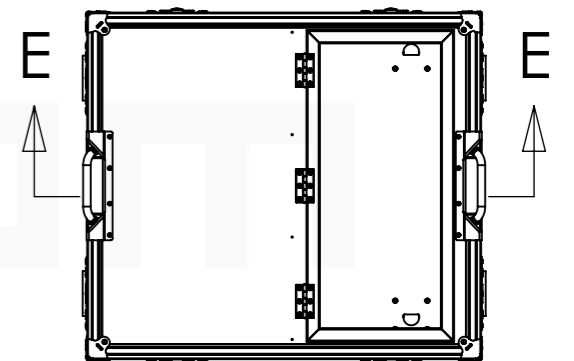
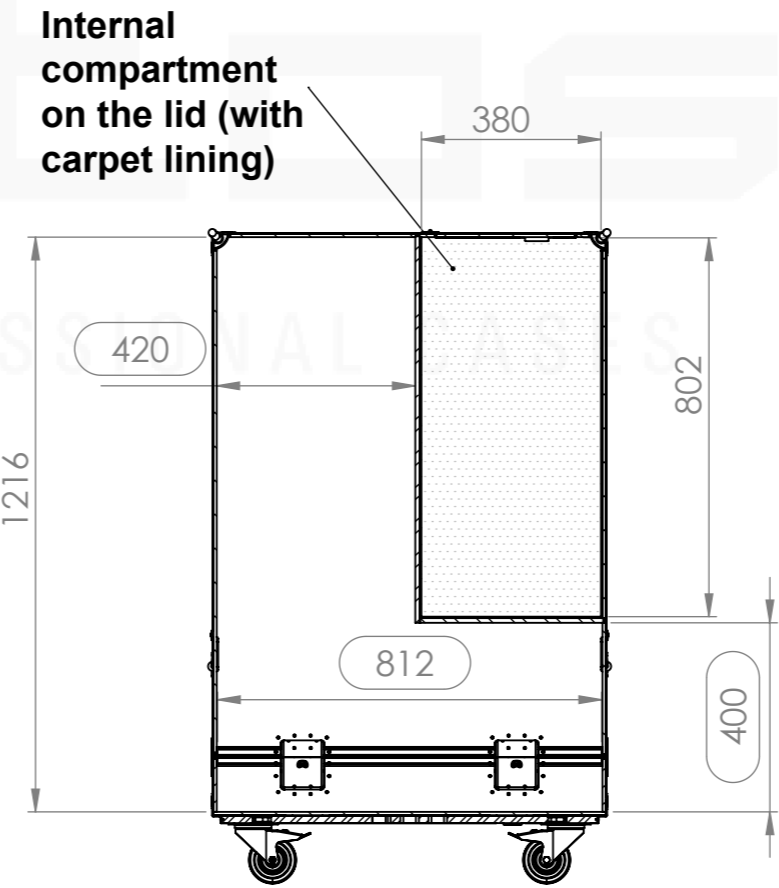
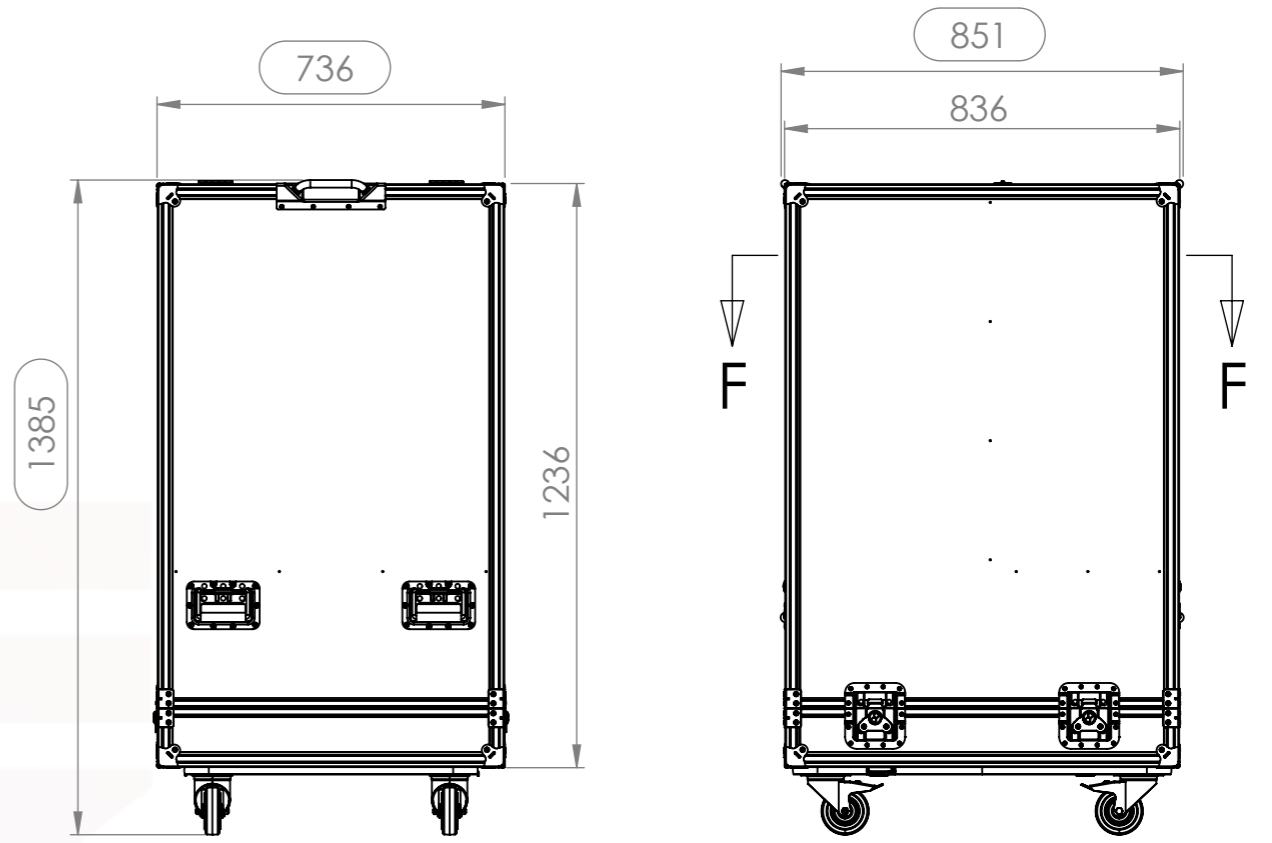
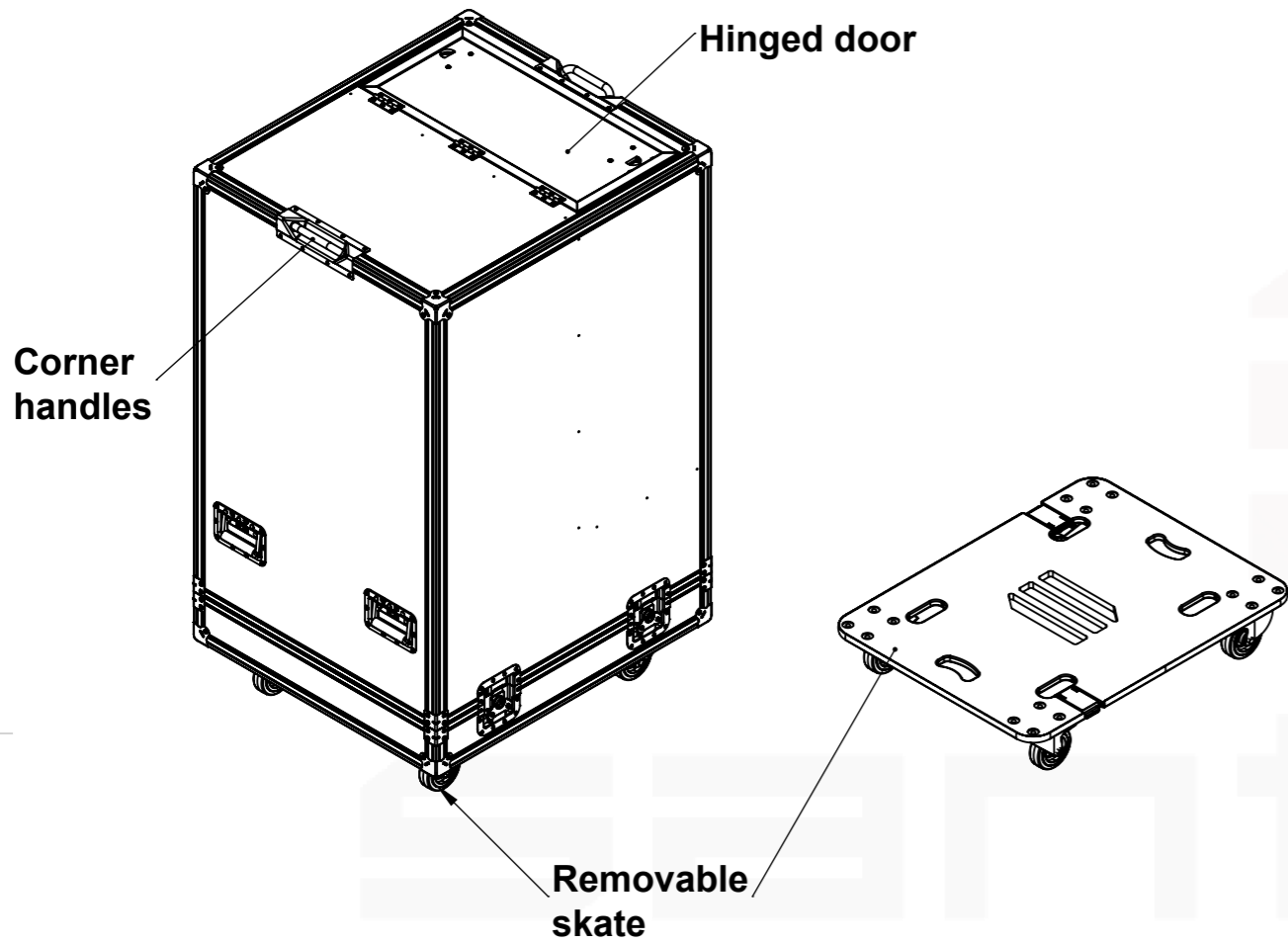

Hardware		
Qty	Ref.	Description
4	34082	Recessed sprung handle medium model
8	4004	Case corner zinc plated
8	40403	Large corner bracket f. 35mm case angle
2	34041	Case edge handle
2	PES.9438	Plastic Feet 94x38x15mm
2	PES.9438	Plastic feet for ASD3 System
6	16540	Sliding Latch System - Sliding Latch
4	172531	Large butterfly V3 with 'push-back' function
3	2602	Medium duty butt hinge z./p.
4	RODA.100T	Swivel castor Ø100mm with brake

SECTION E-E

SECTION F-F

This drawing must not be copied or disclosed without consent of the owner

Drawn by	Name	Date
alexandre	alexandre	02/03/2017
Reference	2803.001	
Scale	units in mm	general tolerance
1:16	DO NOT SCALE	0.8mm
1st Angle projection	FC. 800X700X1200 + SKATE AMOVÍVEL	

