

Internal Dimensions		
Width	Depth	Height
19"	580	3Un
Weight	Approx. 17 Kg	
Wall Thickness	7mm	

REVISIONS				
ZONE	REV.	DESCRIPTION	DATE	APPROVED
-	0	Final Drawing	01/11/2013	Daniel Lopes
-	1	Final Drawing	10/05/2017	Jorge Pacheco

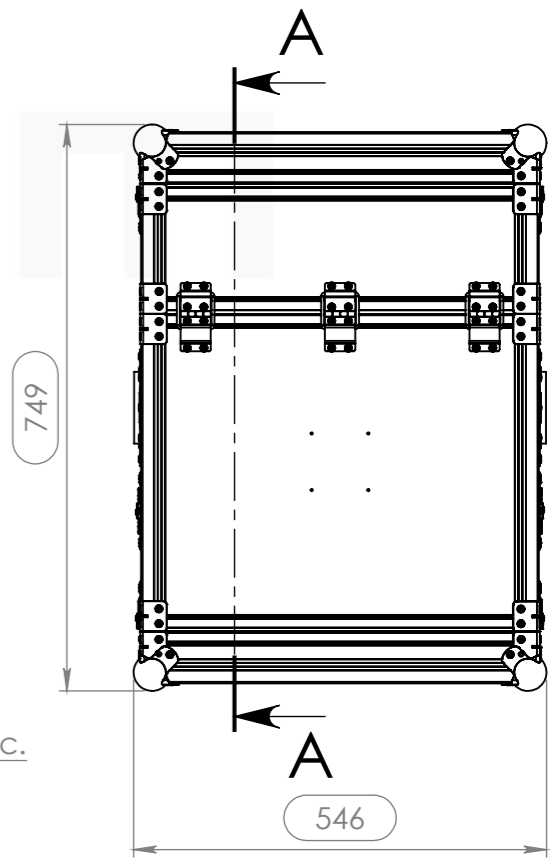
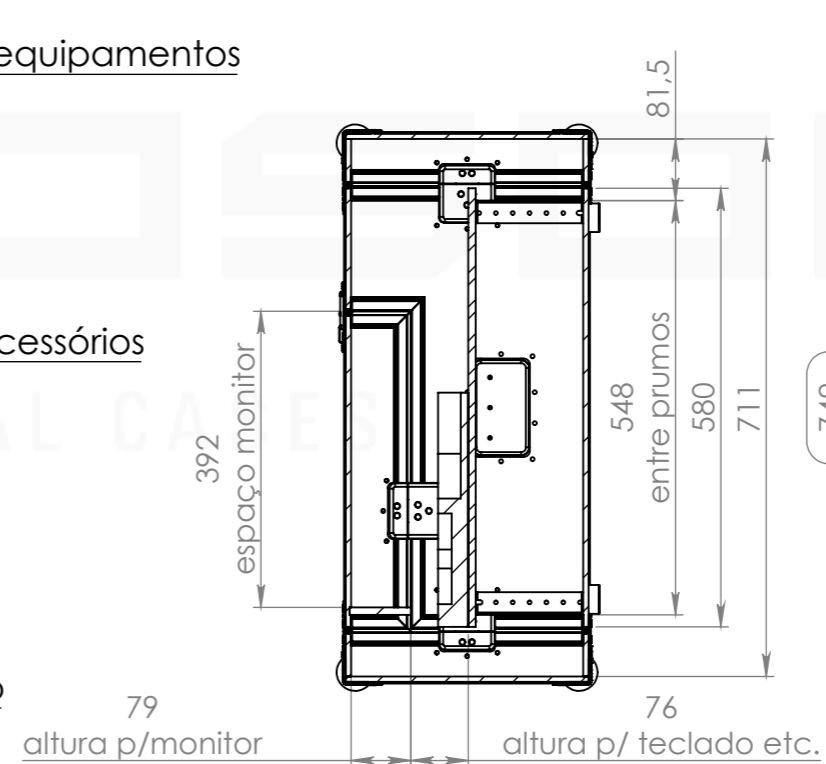
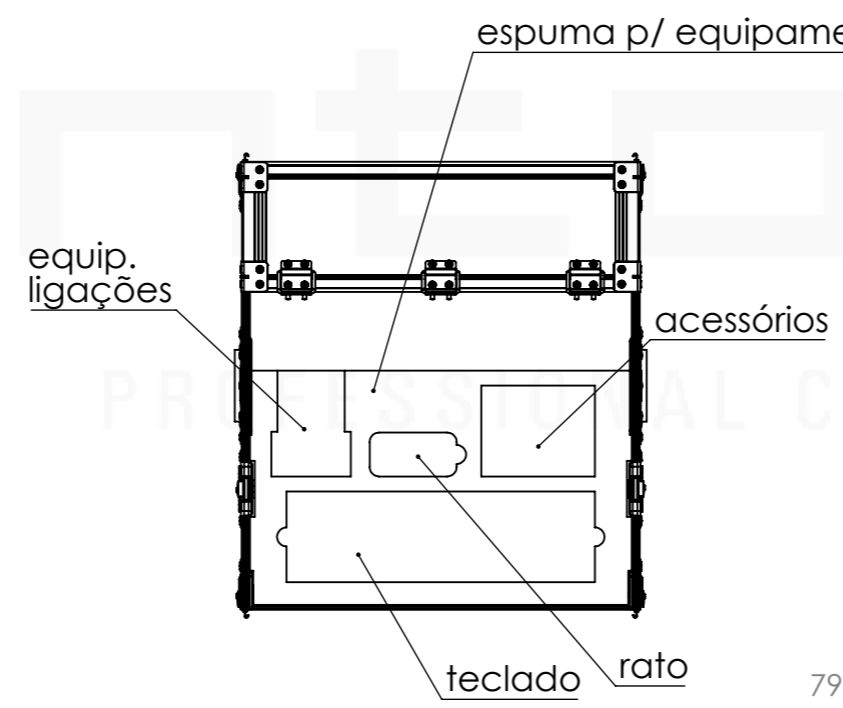
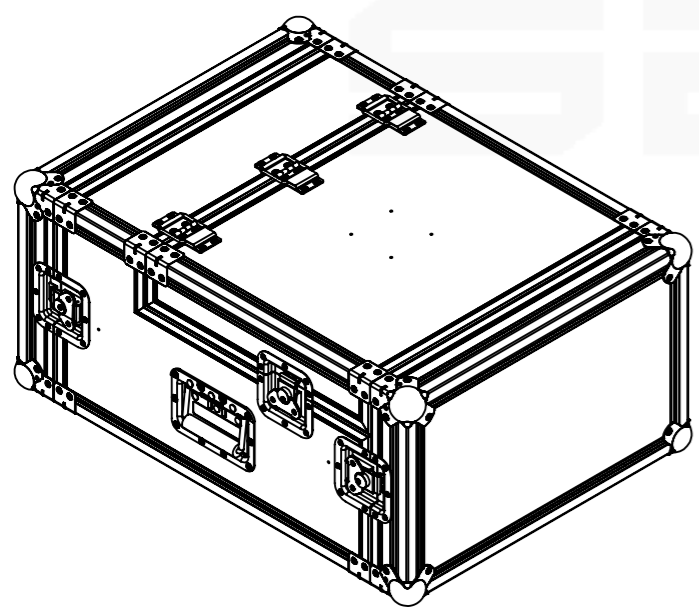
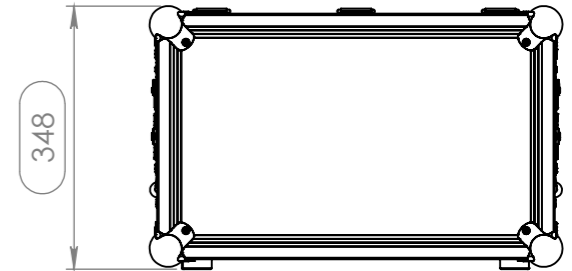
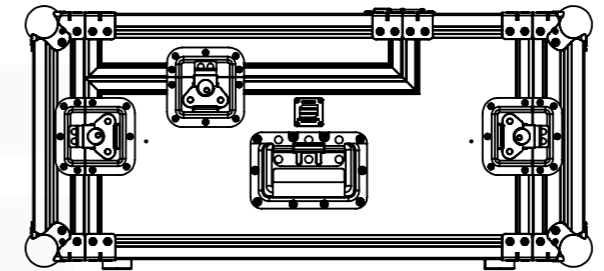
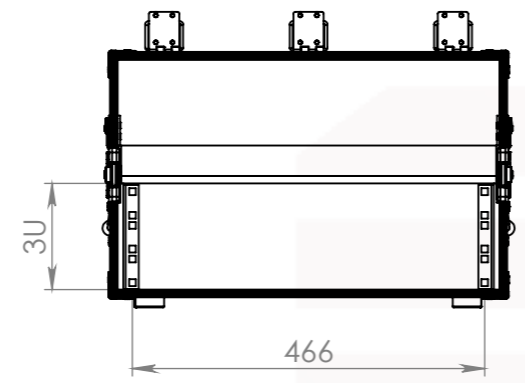
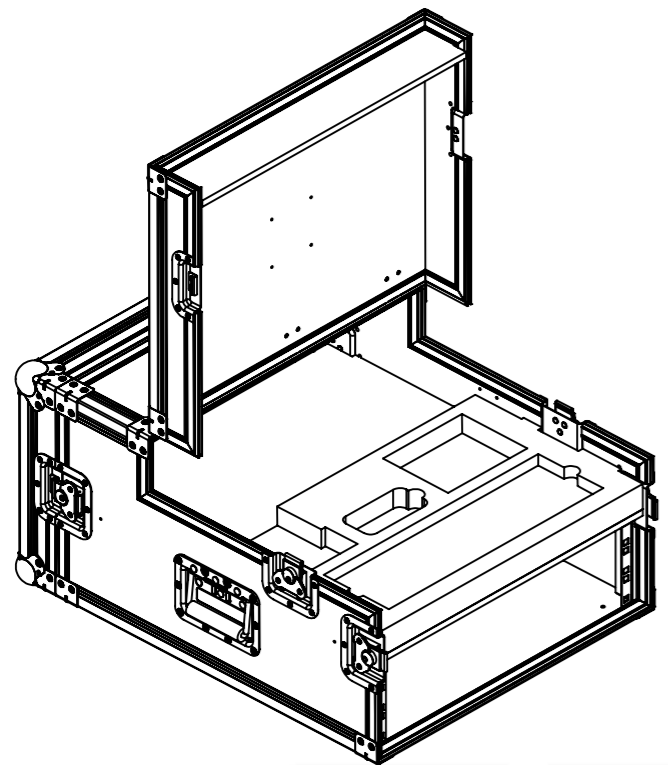

Hardware		
Qty	Ref.	Description
20	40403	Large corner bracket f. 35mm case angle
8	4120	Heavy duty ball corner, zinc plated
4	4907	Rubber foot 38mm x 15 mm
6	17290S	Key lockable medium Butterfly special
2	34082	Recessed Sprung Handle Medium

This drawing must not be copied or disclosed without consent of the owner

Drawn by	Name	Date
jorgepacheco	jorgepacheco	10/05/2017
Reference	264.100	
Scale	units in mm	general tolerance
1:10	DO NOT SCALE	0.8mm
1st Angle projection		
RACK 19" 3 TAMPAS SU REGIE VIDEO		

