

Revision Table				
Index	Rev.	Description	Date	Draw
-	0	Final Drawing	15-03-2016	Ezequiel Cambao

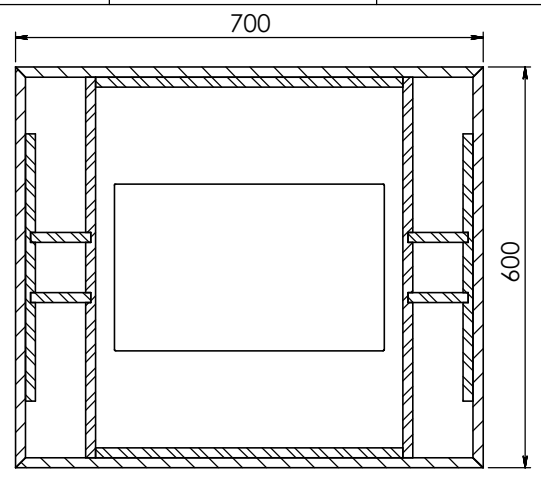

SECTION C-C

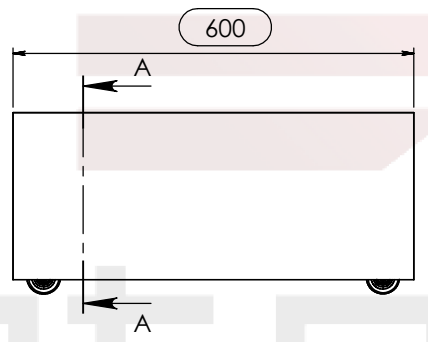
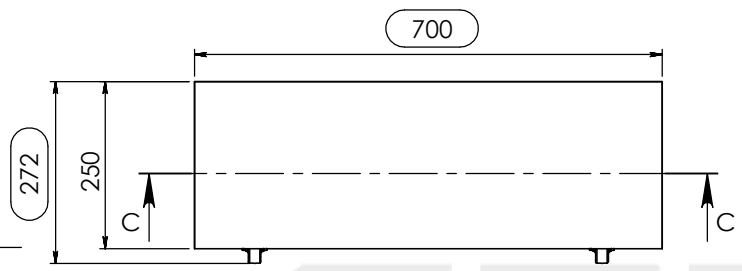

SECTION A-A

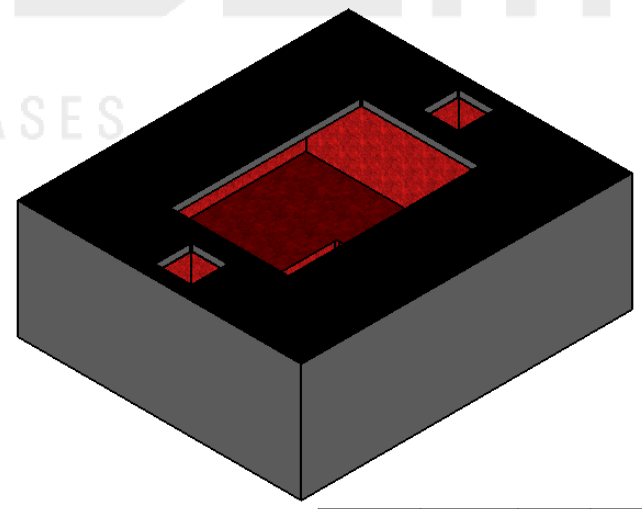
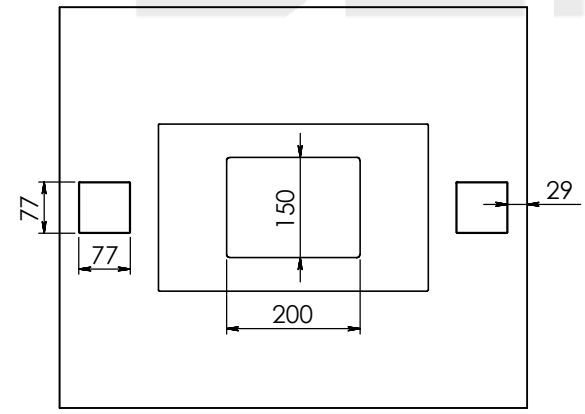
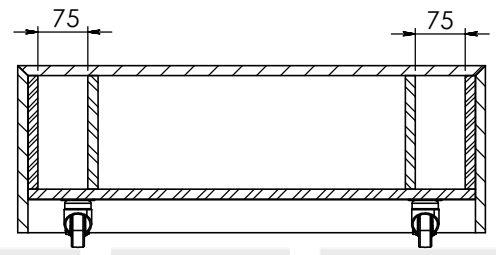

Hardware		
Qty	Ref.	Description
2	3703	Swivel Castor 50 mm with grey Wheel and Brake
2	3701	Swivel Castor 50 mm with gray wheel

This drawing must not be copied or disclosed without consent of the owner

Scale	1:8	UNITS in mm	general tolerance	0.8mm
Reference	ELEMENTO INTERIOR 700X600X250 MM EXPOSITOR A88			

