

Interior dimensions		
Width	Depth	Height
570	404	143
Weight	Approx. 6 Kg	
Wall Thickness		7mm

REVISIONS				
ZONE	REV.	DESCRIPTION	DATE	APPROVED
-	-	Final Drawing	24/10/2014	Daniel Lopes

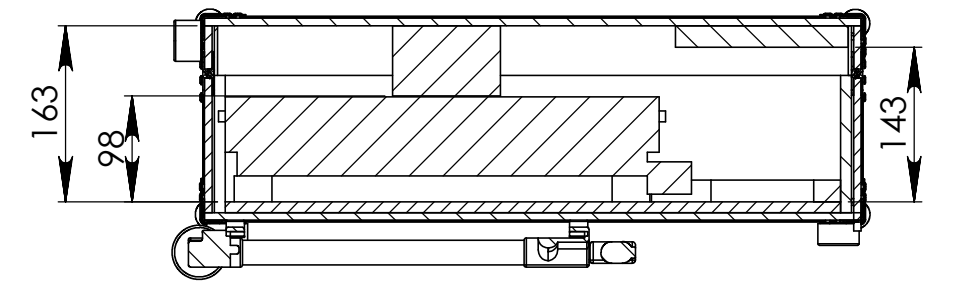

SECTION A-A

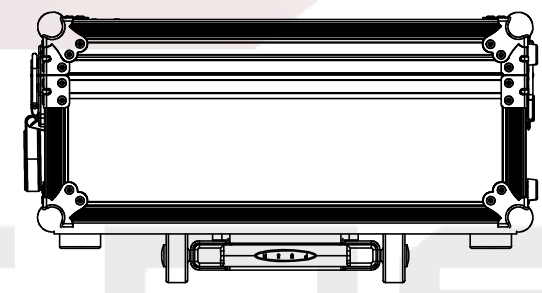
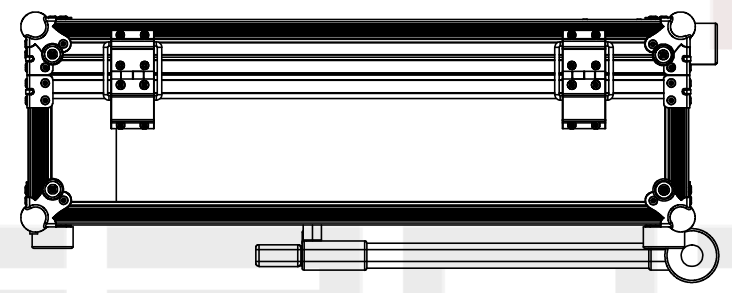
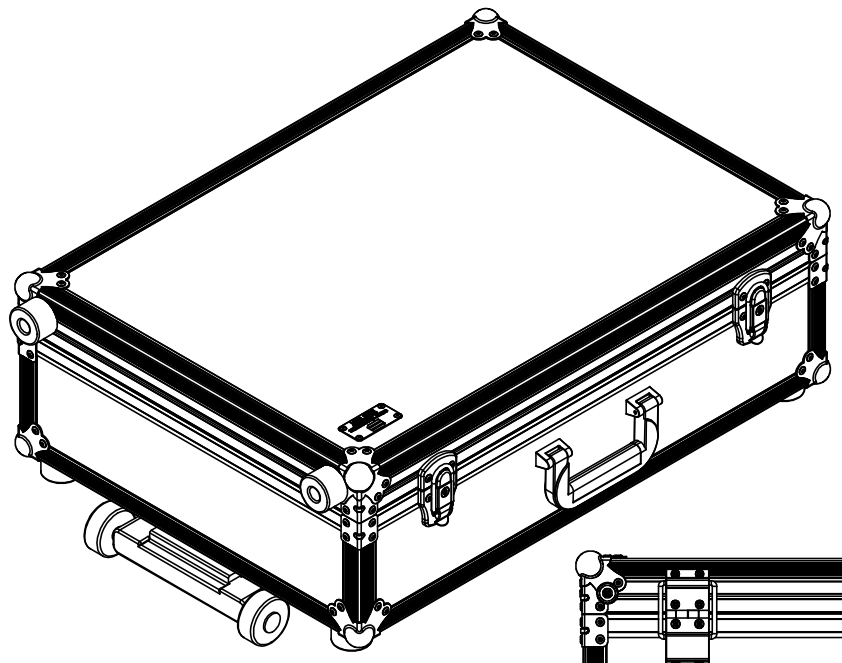
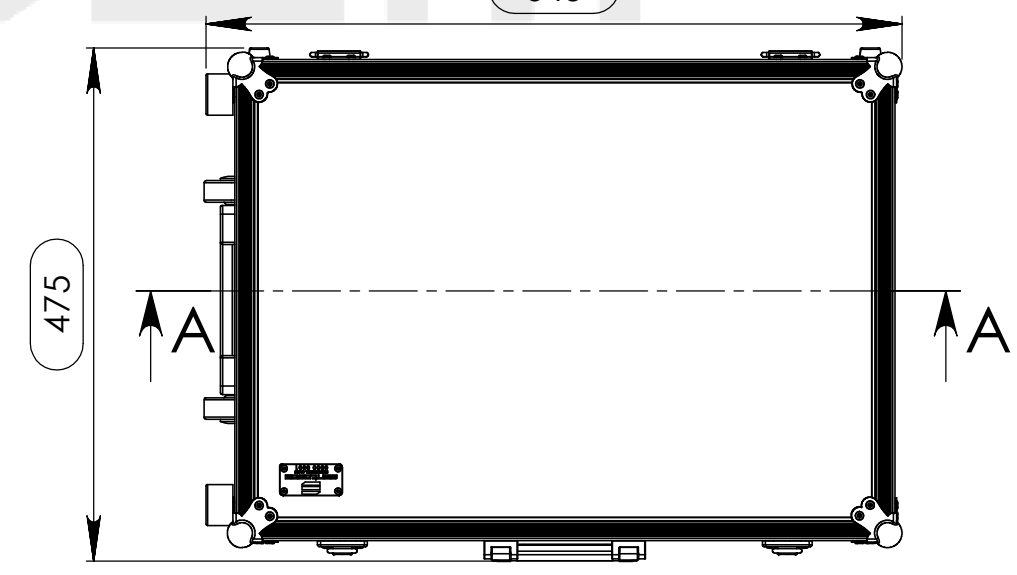
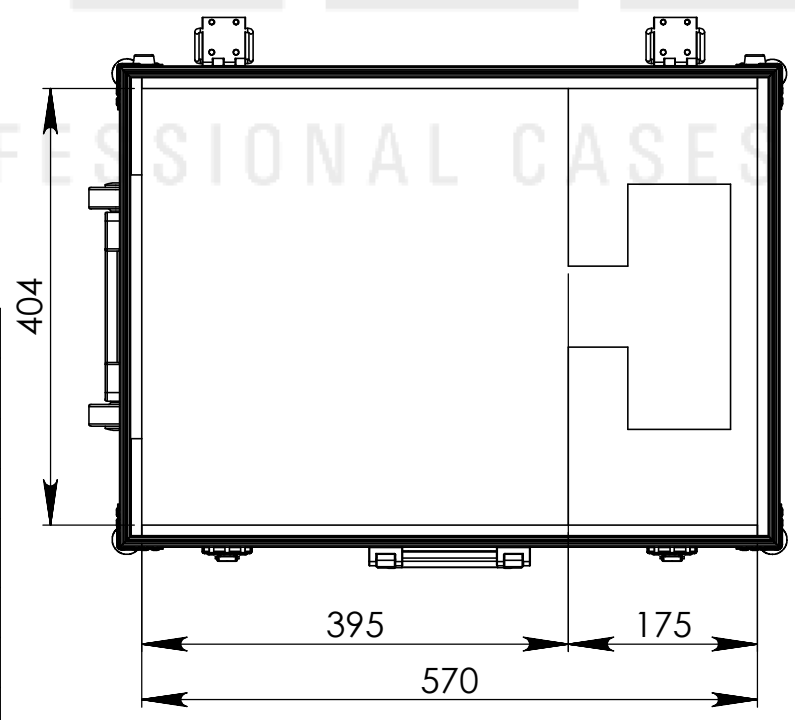
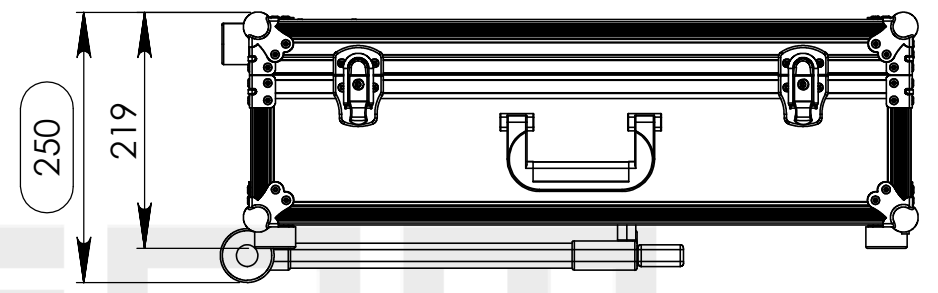

Hardware		
Qty	Ref.	Description
8	40407	Medium corner-brace zinc plated 1,0mm
8	C1345Z	Small ball corner - 3 leg - zinc plated
1	3430	Chrome plated plastic with soft black plastic insert
2	2524	Heavy Duty Strut Hinge, zinc plated
2	1903	Heavy drawbolt with lock chrome
4	4903	Rubber foot 20 x 9 mm, black
4	4909	38 mm rubber foot black with steel insert. Height: 20 mm.
1	3472	Removable Case Trolley
2	4911	Rubber foot 38 x 25 mm with steel insert

This drawing must not be copied or disclosed without consent of the owner

Drawn by	Name	Date
DanielLopes	DanielLopes	24-10-2014
Reference	2270.100	
Scale	units in mm	general tolerance
1:7	DO NOT SCALE	0.5mm
1st Angle projection	MULTICASE PARA BALANÇAS BARCELBAL	



A3