

Interior dimensions		
Width	Depth	Height
550	550	400
Weight	Approx. 13 Kg	
Wall Thickness	7mm	

REVISIONS				
ZONE	REV.	DESCRIPTION	DATE	APPROVED
-	-	Final Drawing	26/11/2014	Daniel Lopes

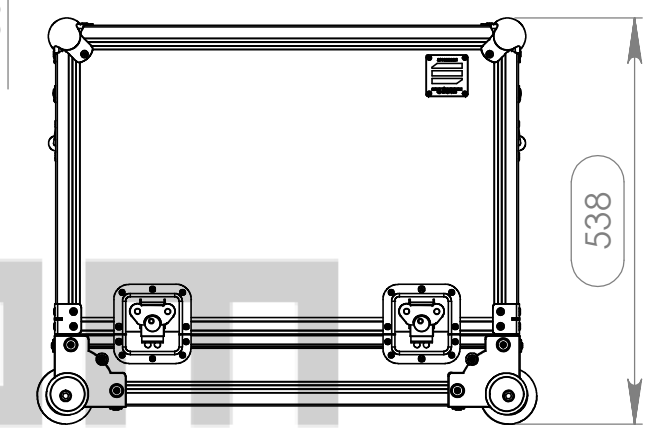

PROFESSIONAL CASES

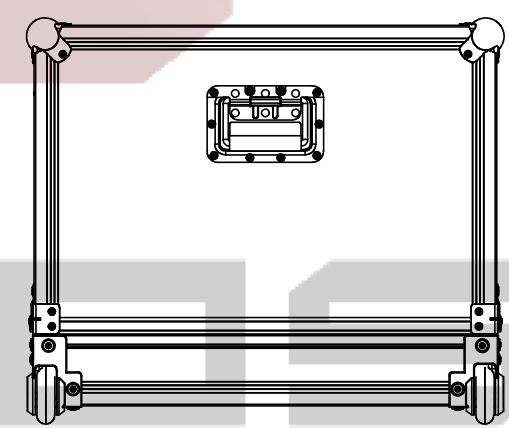
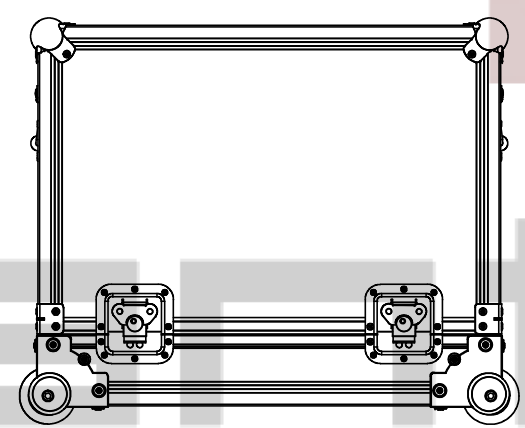
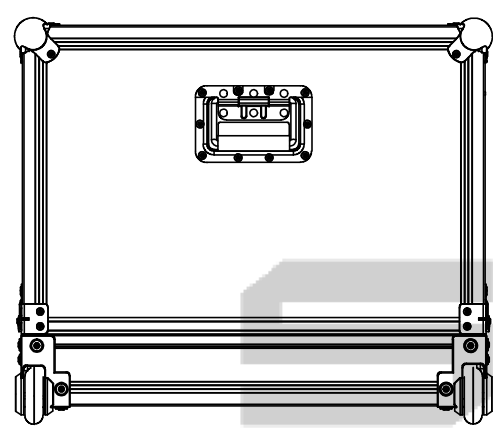
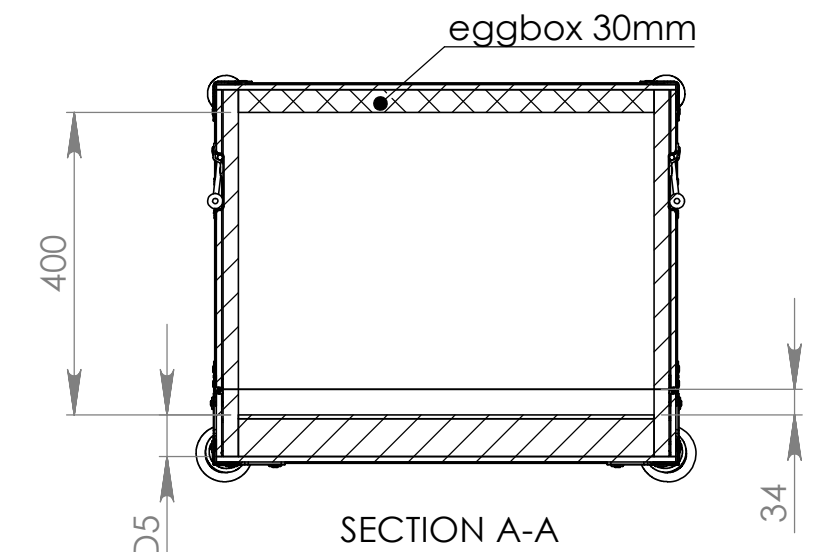
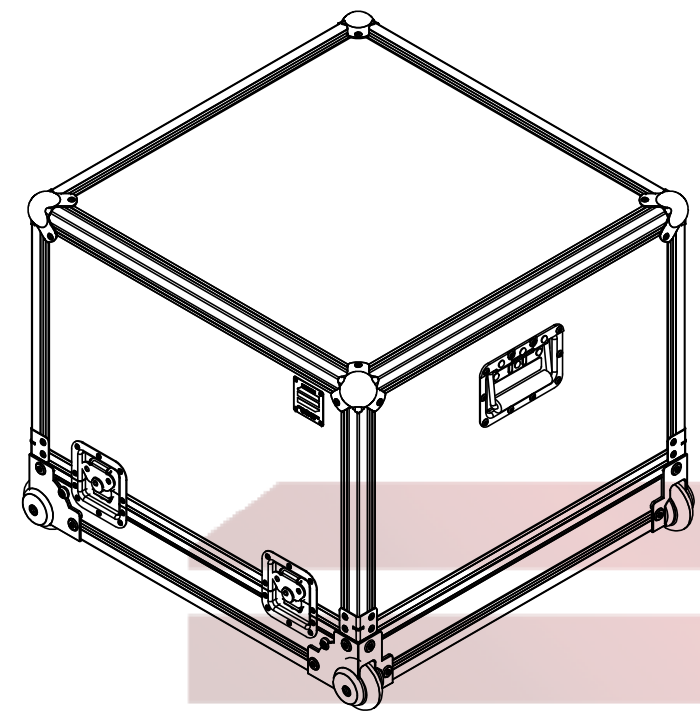
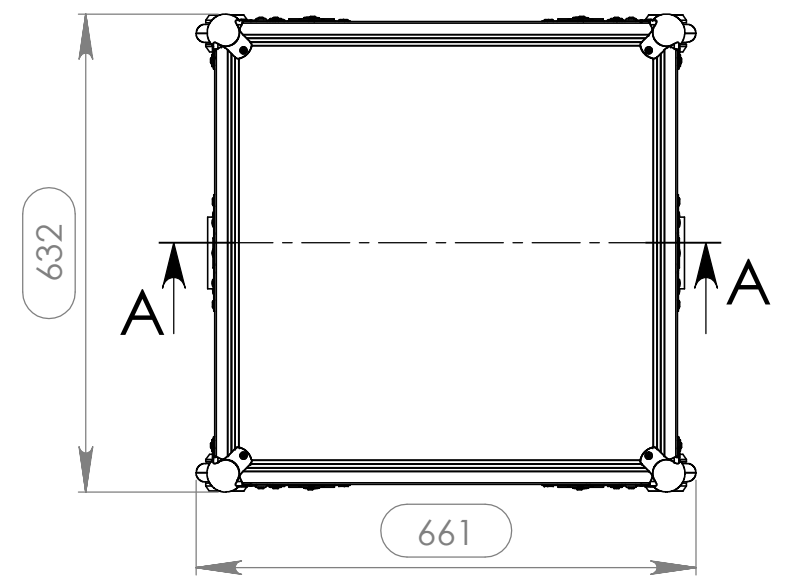
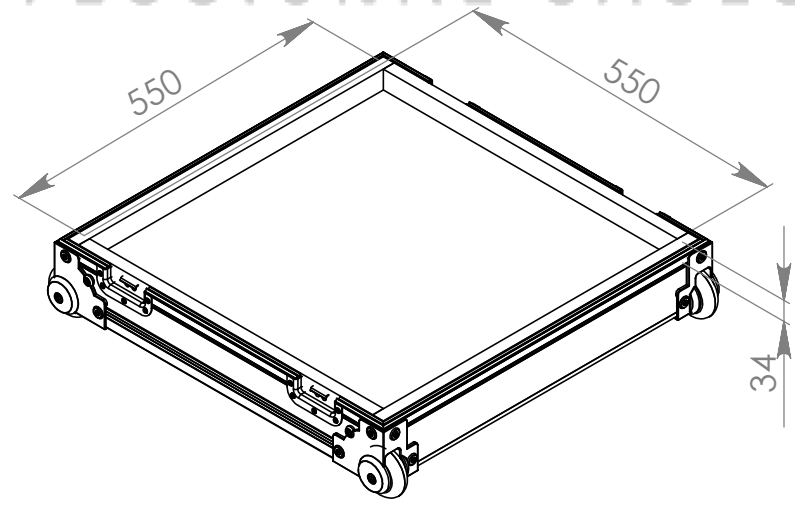

Hardware		
Qty	Ref.	Description
4	17290S	Key lockable medium Butterfly special
2	34082	Recessed sprung handle medium model
4	40403	Large corner bracket f. 35mm case angle
4	4120	Medium ball corner zinc plated
4	37451	Recessed Corner Castor 75mm, Die-Cast Housing

This drawing must not be copied or disclosed without consent of the owner

Drawn by	Name	Date
DanielLopes	DanielLopes	26-11-2014
Reference	2264.102	
Scale	units in mm	general tolerance
1:10	DO NOT SCALE	±0.8mm
1st Angle projection	FC.MÁQUINA LASER BODYCULT 550X550X400MM., RODAS	

