

Interior dimensions		
Width	Depth	Height
3200	1000	1050
Weight	Approx. 148 Kg	
Wall Thickness	10mm	

REVISIONS				
ZONE	REV.	DESCRIPTION	DATE	APPROVED
-	0	Final Drawing	19/09/2014	Daniel Lopes

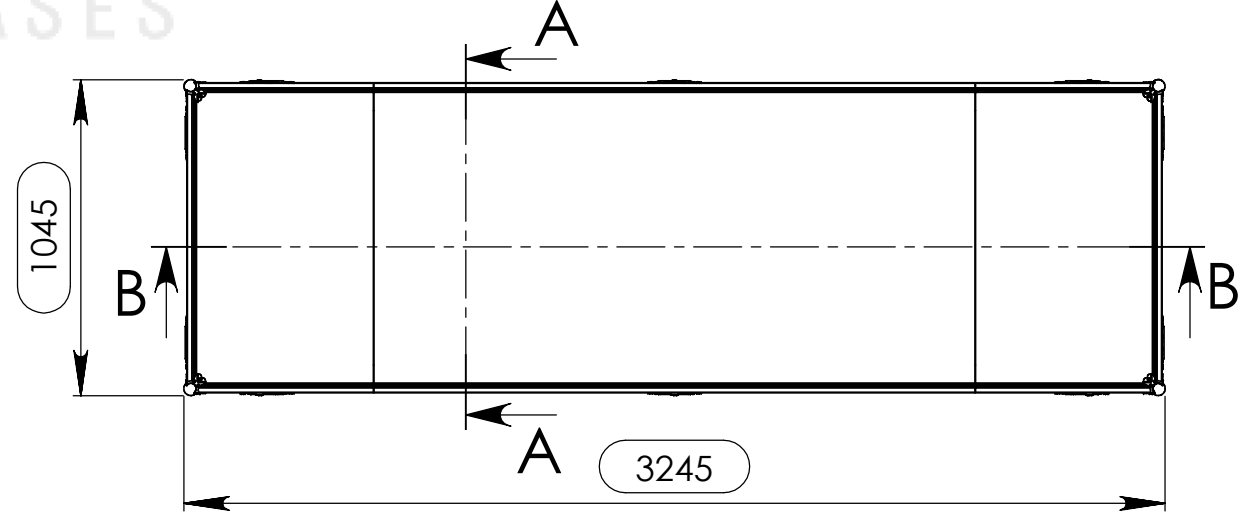
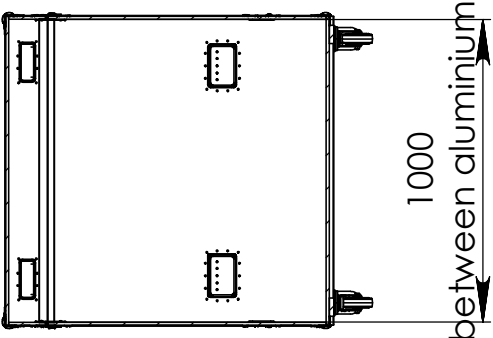
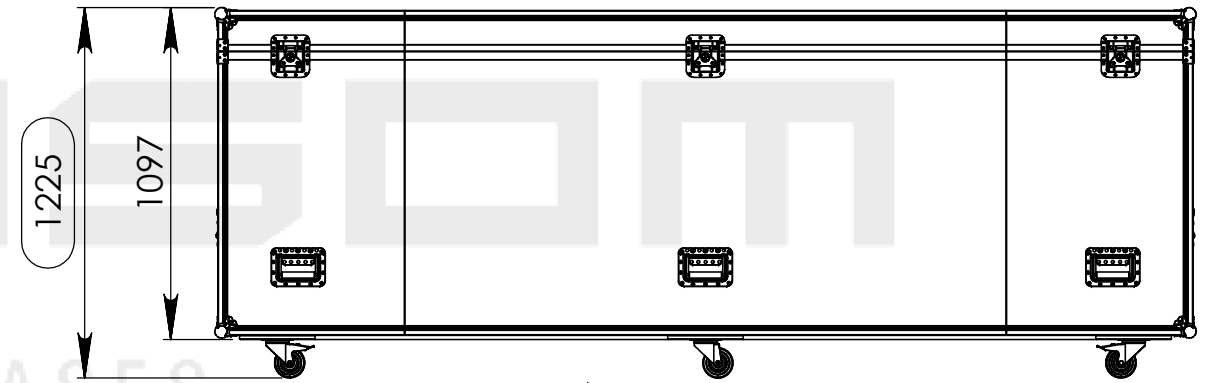
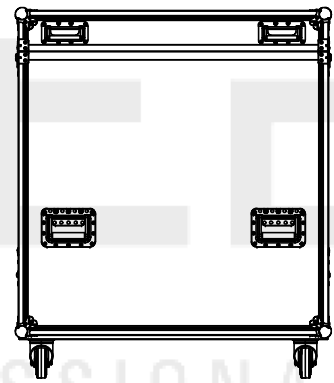
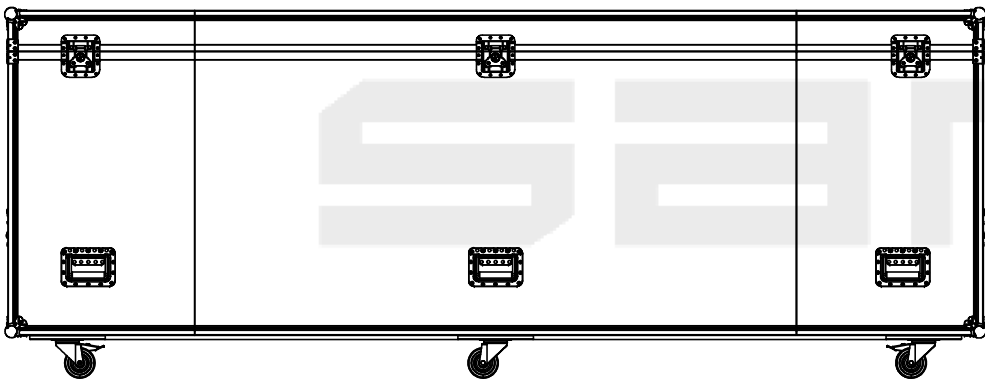
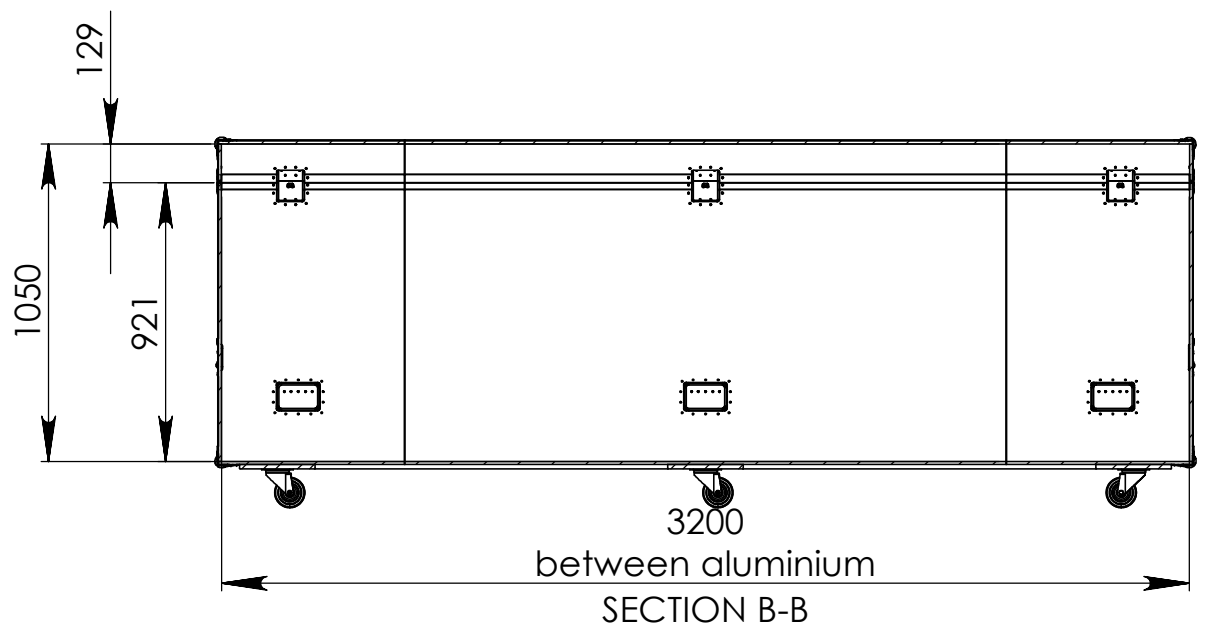
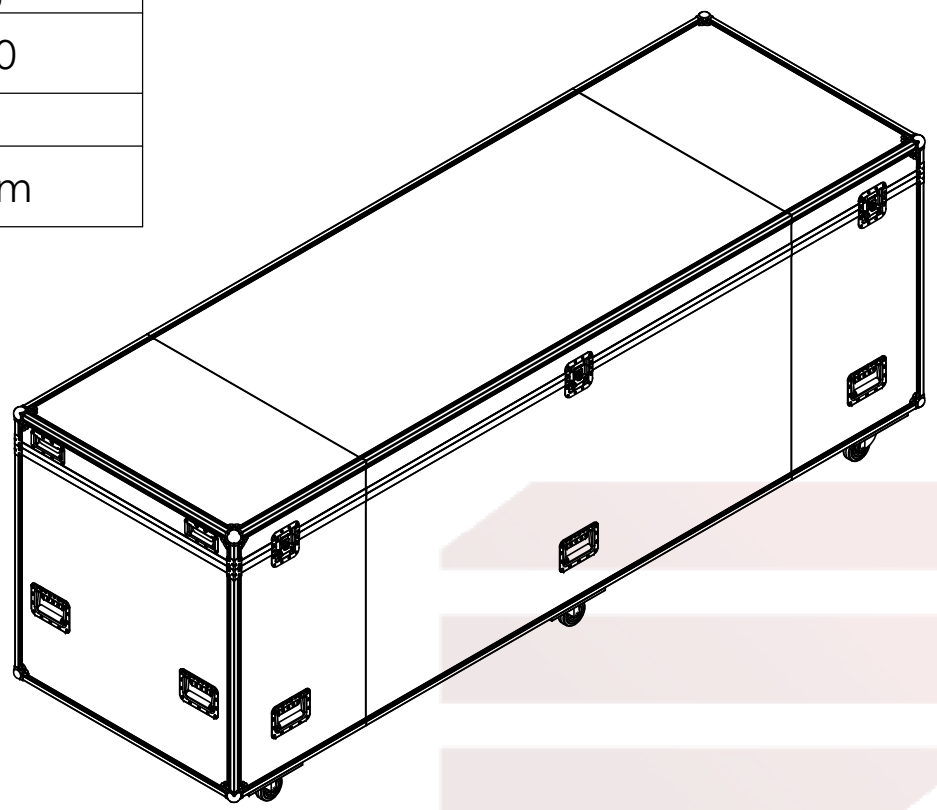

Hardware		
Qty	Ref.	Description
8	40403	Large corner bracket f. 35mm case angle
6	172531	Large butterfly V3 with 'push-back' function
2	RODA.100T	Swivel castor Ø100mm with brake
4	RODA.100	Swivel castor Ø100 mm
4	340822	Recessed sprung handle - Small
8	410429	Ball Corner large three-leg cranked 35 mm 9 holes
10	34085	Large, heavy duty, recessed sprung handle

This drawing must not be copied or disclosed without consent of the owner

Drawn by	Name	Date
DanielLopes	DanielLopes	19-09-2014
Reference	2252.103	
Scale	units in mm	general tolerance
1:25	DO NOT SCALE	±0.5mm
1st Angle projection	FC, TORRE CARRINHOS PIT STOP, RODAS	

