

| REVISIONS |      |               |            |              |
|-----------|------|---------------|------------|--------------|
| ZONE      | REV. | DESCRIPTION   | DATE       | APPROVED     |
| -         | 0    | Final Drawing | 21/03/2014 | Daniel Lopes |

| Interior dimensions |                |        |
|---------------------|----------------|--------|
| Width               | Depth          | Height |
| 2300                | 950            | 1360   |
| Weight              | Approx. 112 Kg |        |
| Wall Thickness      | 9mm            |        |

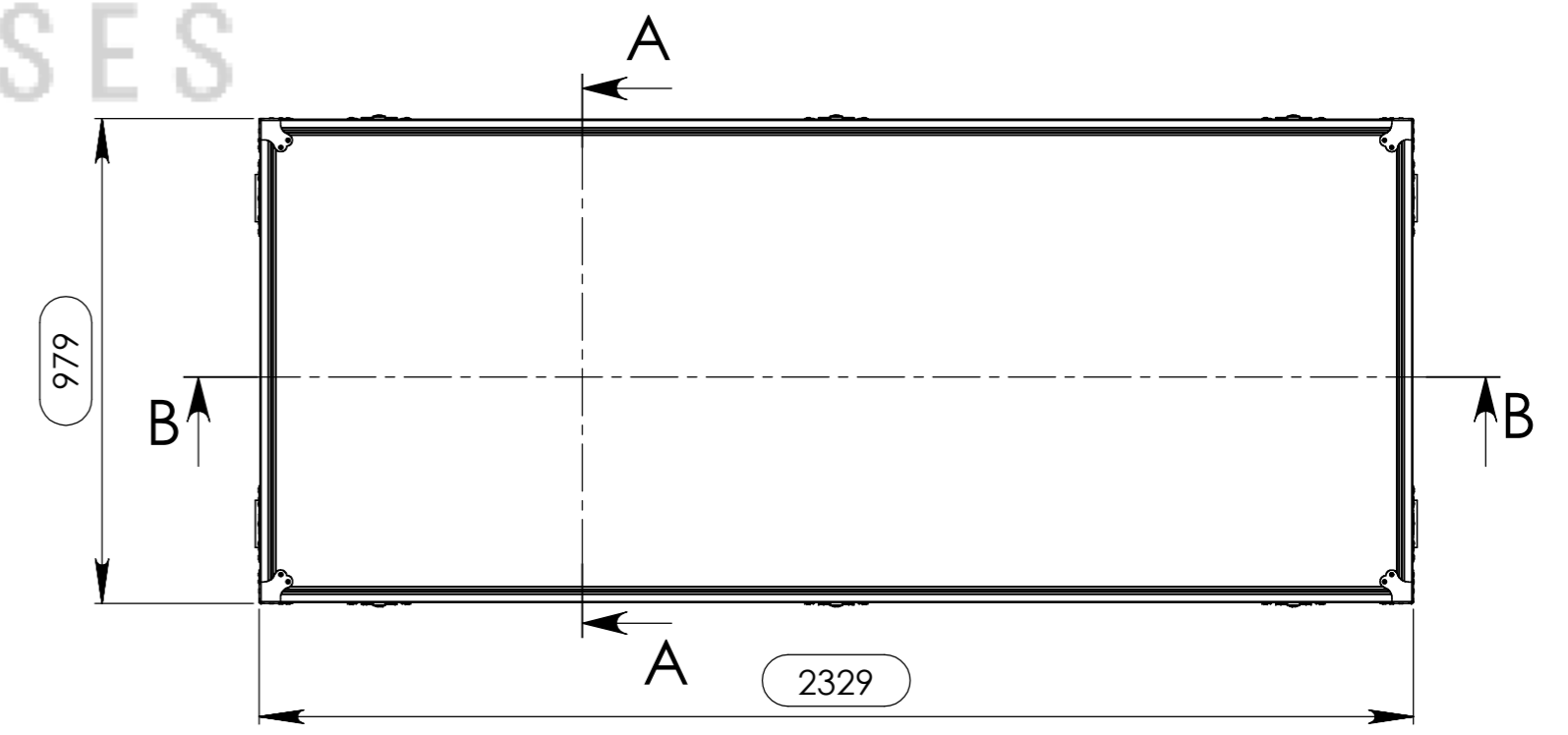
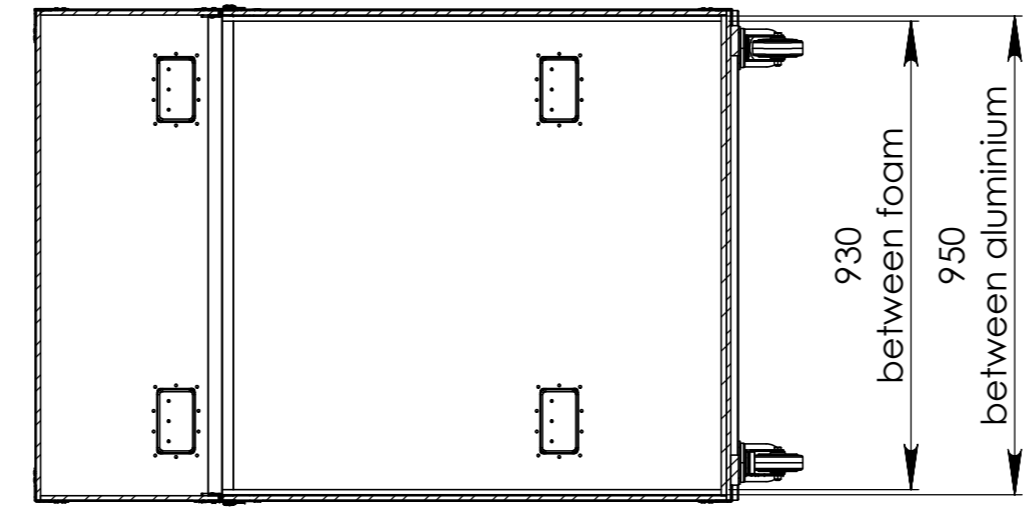
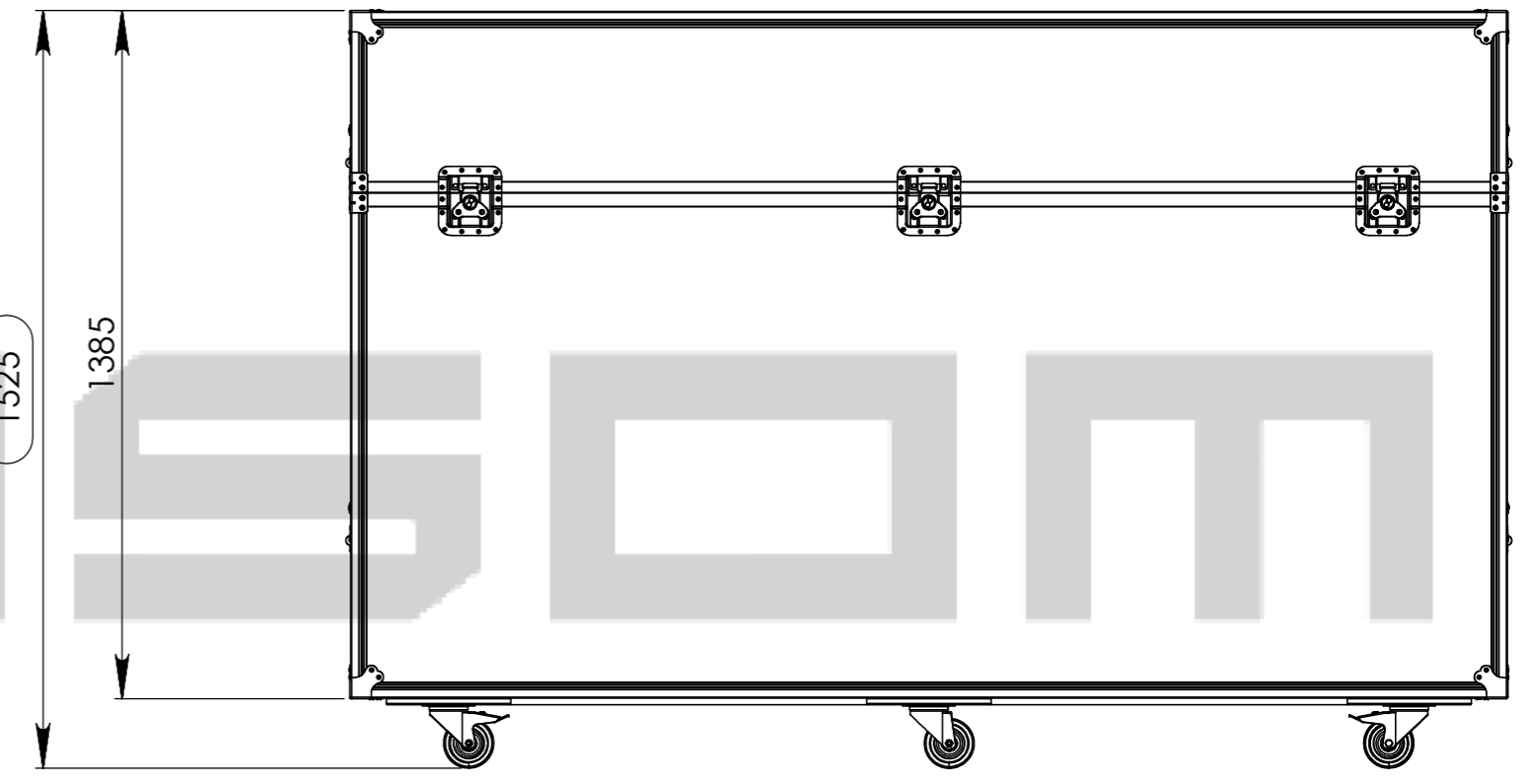
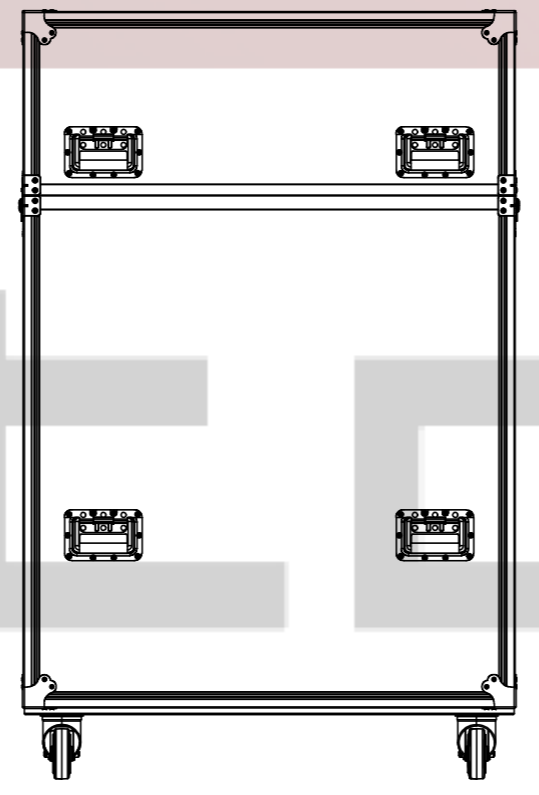
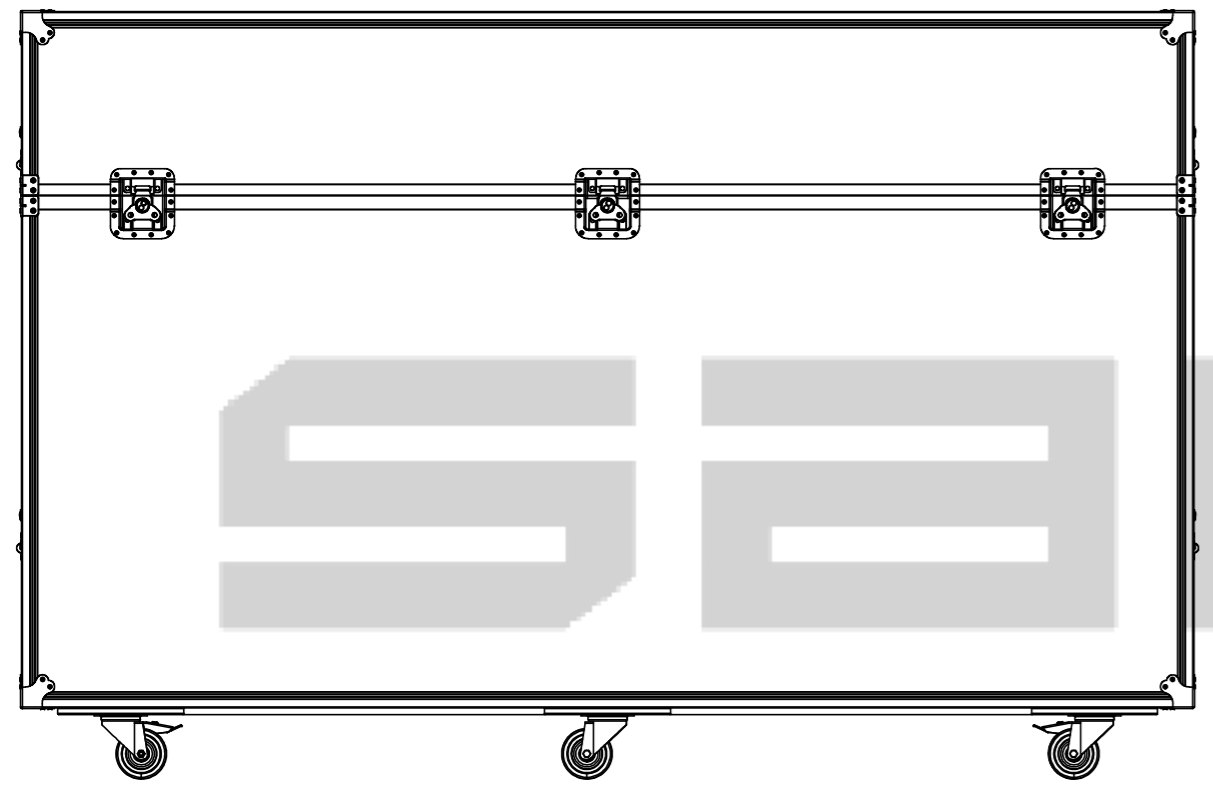
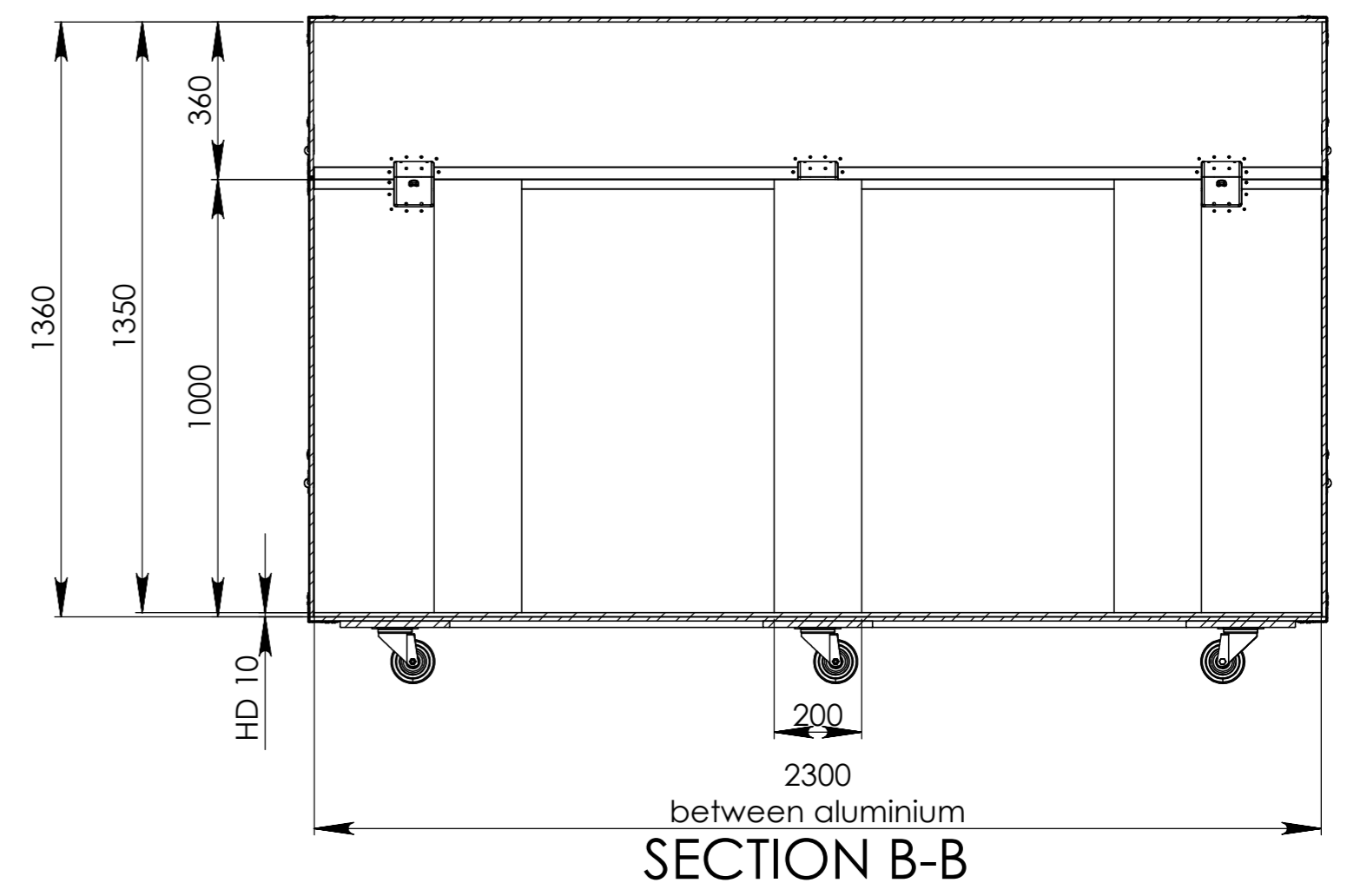
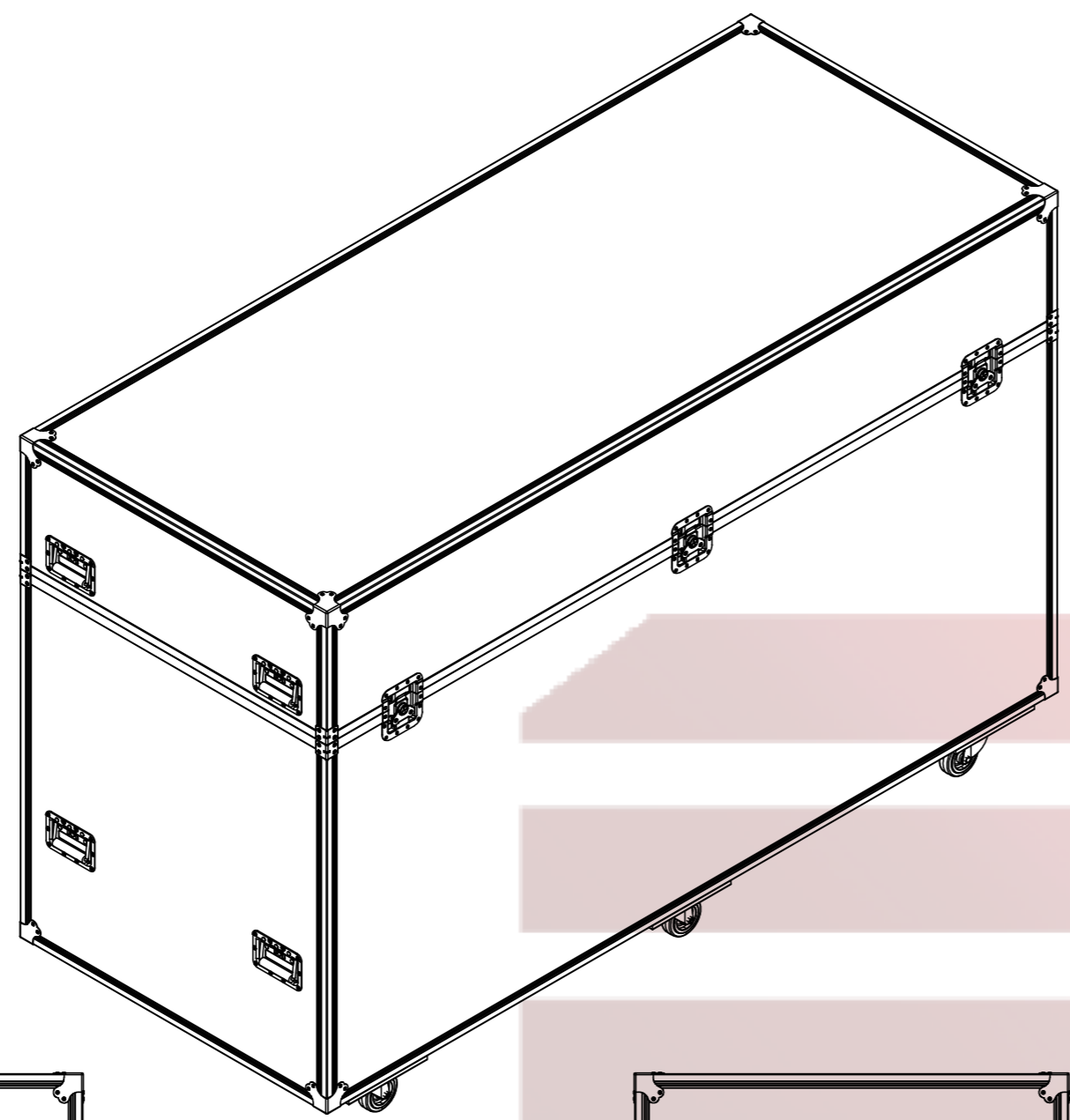

| Hardware |           |                                              |
|----------|-----------|----------------------------------------------|
| Qty      | Ref.      | Description                                  |
| 8        | 40403     | Large corner bracket f. 35mm case angle      |
| 8        | 4150      | Case corner three-leg                        |
| 6        | 172531    | Large butterfly V3 with 'push-back' function |
| 8        | 34082     | Recessed sprung handle medium model          |
| 2        | RODA.100T | Swivel castor Ø100mm with brake              |
| 4        | RODA.100  | Swivel castor Ø100 mm                        |

| Drawn by     | Name         | Date                                |
|--------------|--------------|-------------------------------------|
| Daniel Lopes | Daniel Lopes | 21-03-2014                          |
| Reference    | 2148.ST19D   |                                     |
| Scale        | 1:15         | general tolerance<br>FC, STAND 9DV3 |

This drawing must not be copied or disclosed without consent of the owner

