

Interior dimensions		
Width	Depth	Height
1830	600	840
Weight	Approx. 60 Kg	
Wall Thickness	9mm	

REVISIONS				
ZONE	REV.	DESCRIPTION	DATE	APPROVED
-	0	Final Drawing	07/03/2014	Daniel Lopes

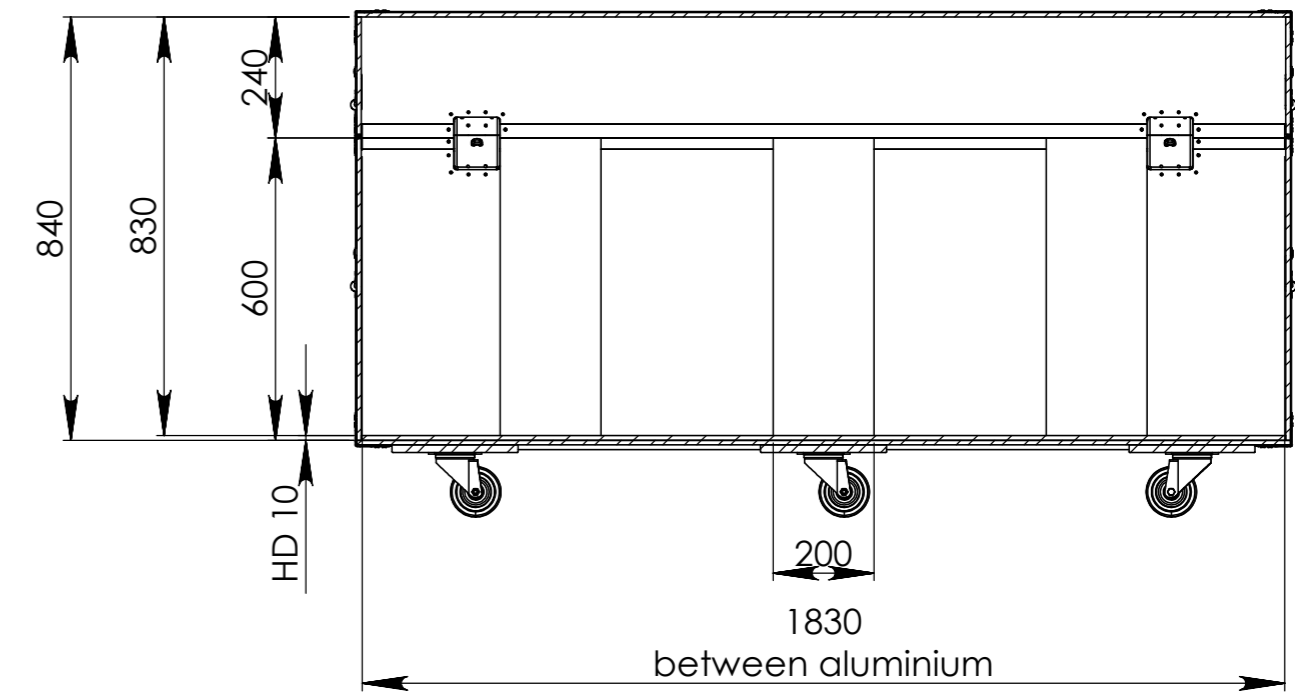

SECTION B-B

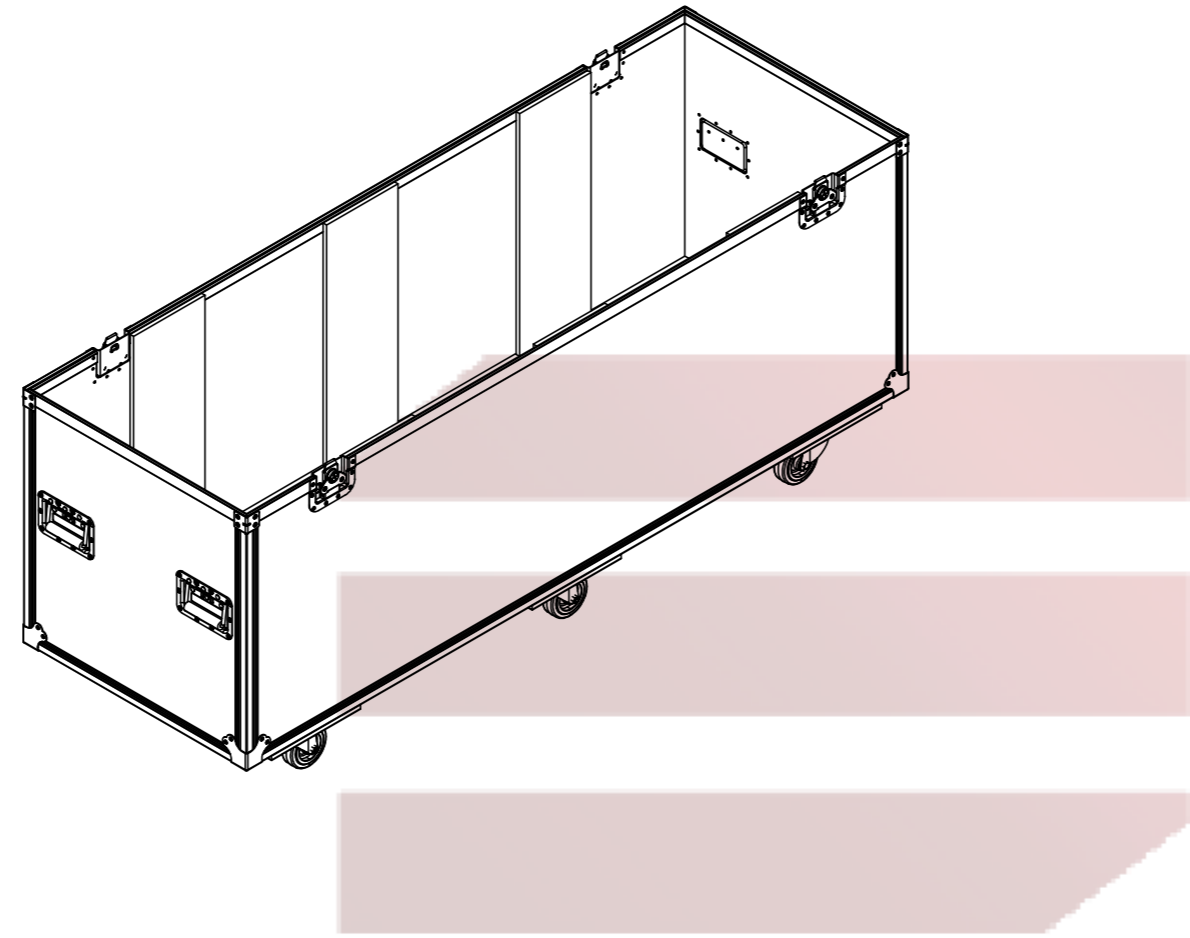
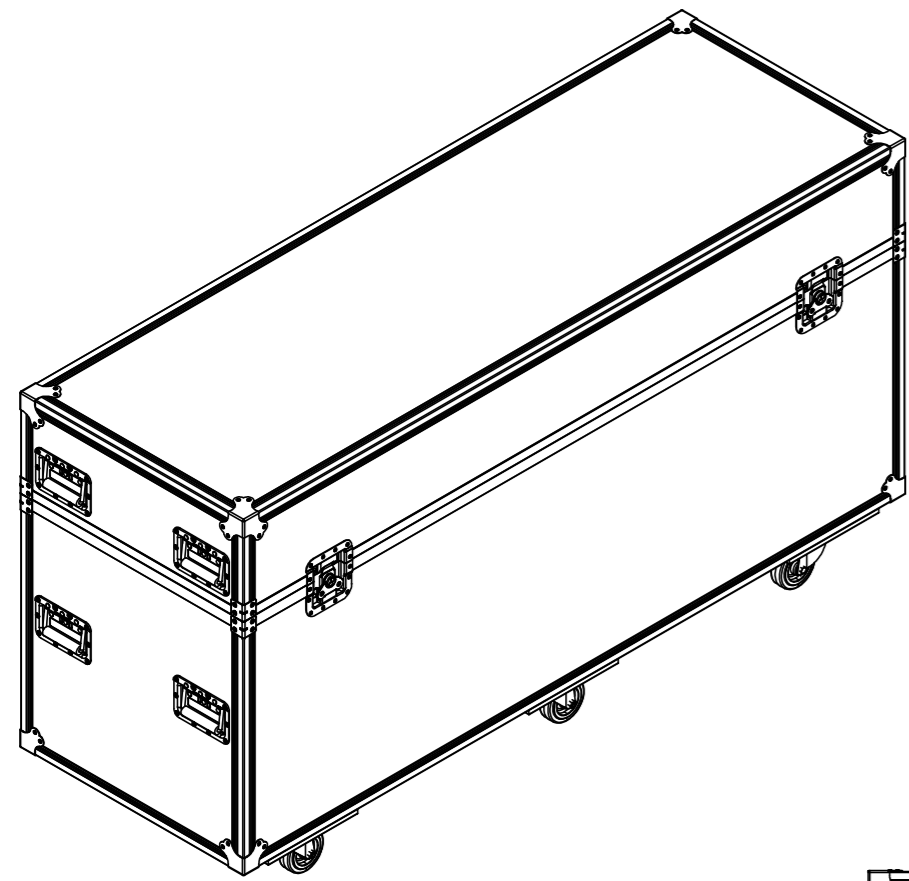
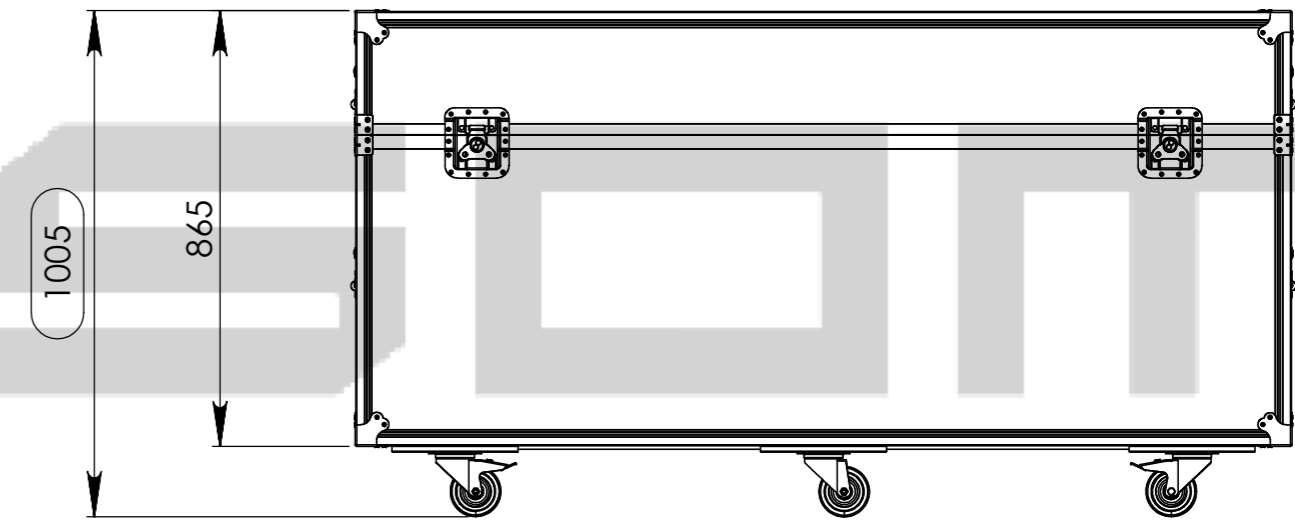
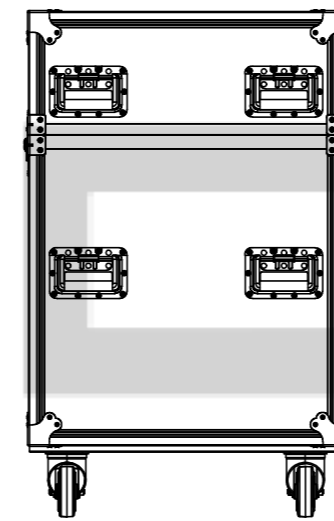
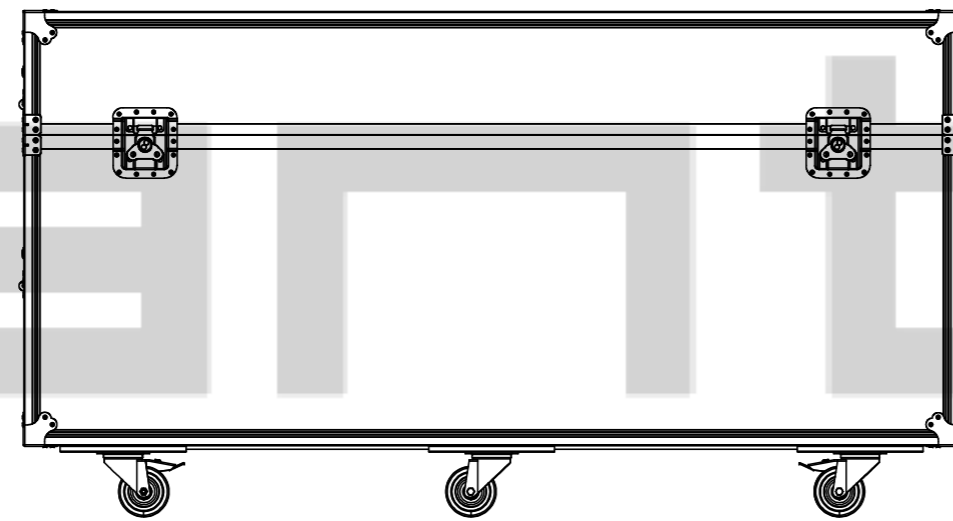

PROFESSIONAL CASES

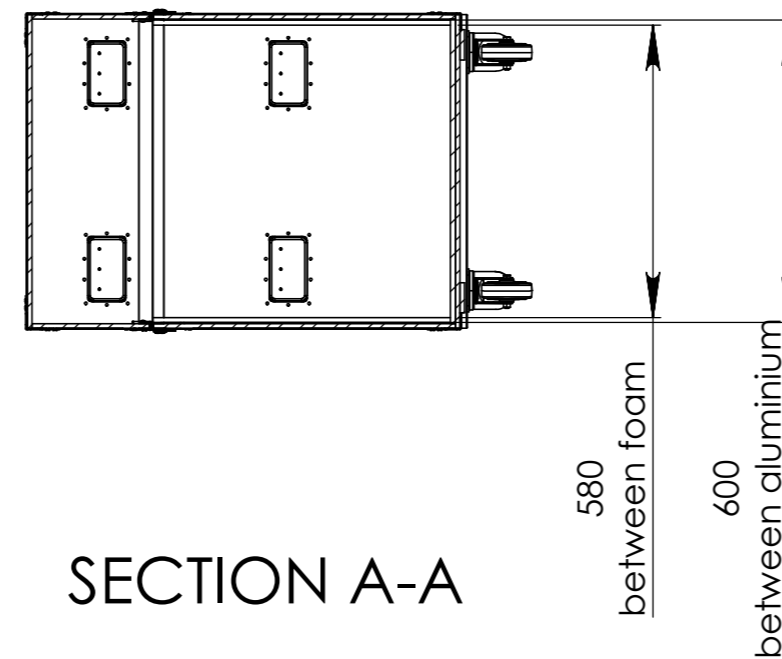

SECTION A-A



Hardware		
Qty	Ref.	Description
8	40403	Large corner bracket f. 35mm case angle
8	4150	Case corner three-leg
4	172531	Large butterfly V3 with 'push-back' function
8	34082	Recessed sprung handle medium model
2	RODA.100T	Swivel castor Ø100mm with brake
4	RODA.100	Swivel castor Ø100 mm

Drawn by	Daniel Lopes	Name	Daniel Lopes	Date	07-03-2014
Reference	2148.S19A	Scale	1:15	general tolerance	±0.8mm
<small>           This drawing must not be copied or disclosed without consent of the owner         </small>		<small>           1st Angle projection         </small>	<small>           DO NOT SCALE         </small>	<small>           FC, Stand 9AV2         </small>	