

Interior dimensions

Width	Depth	Height
2990	710	1040
Weight	Approx. 102 Kg	
Wall Thickness	9mm	

REVISIONS				
ZONE	REV.	DESCRIPTION	DATE	APPROVED
-	0	Final Drawing	25/02/2014	Daniel Lopes

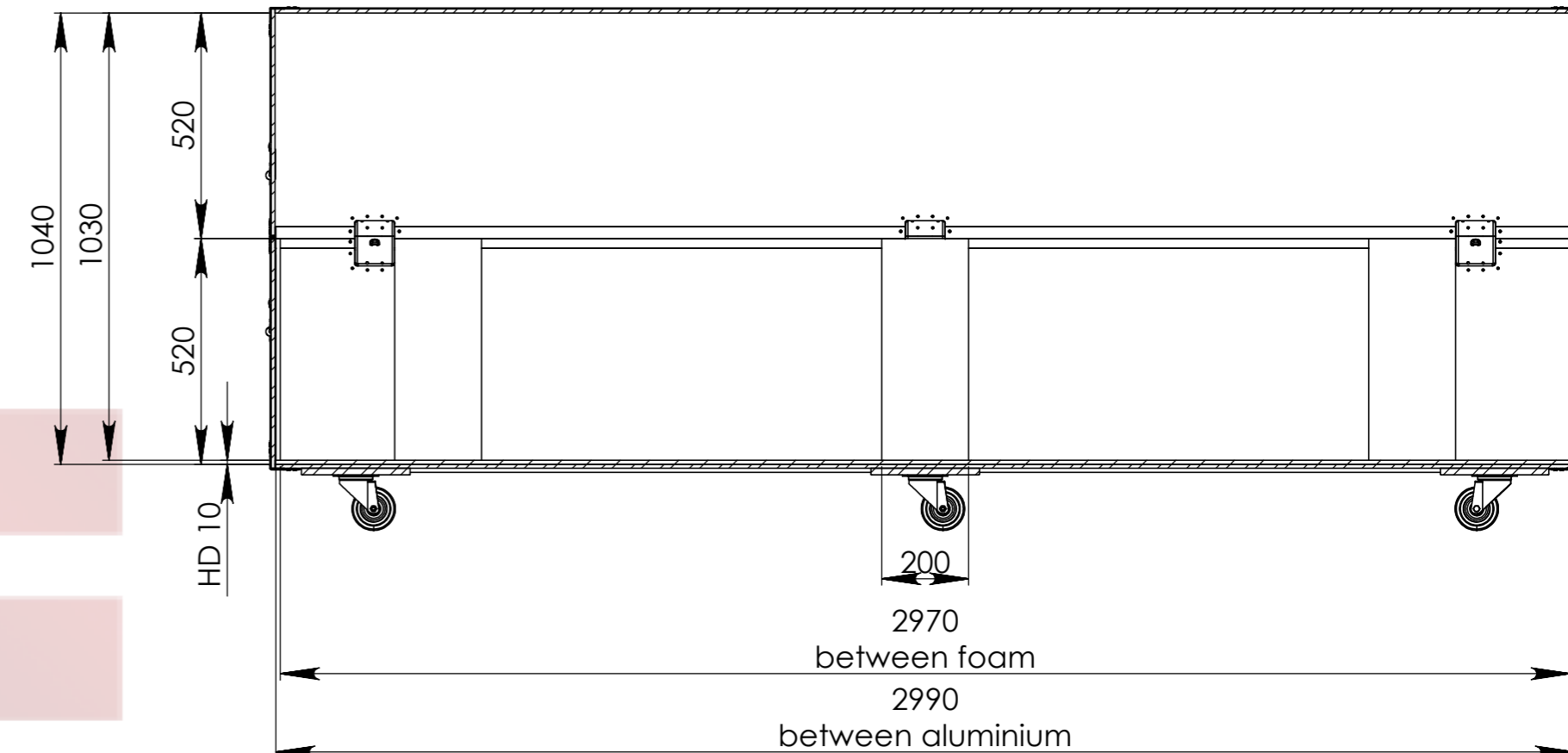
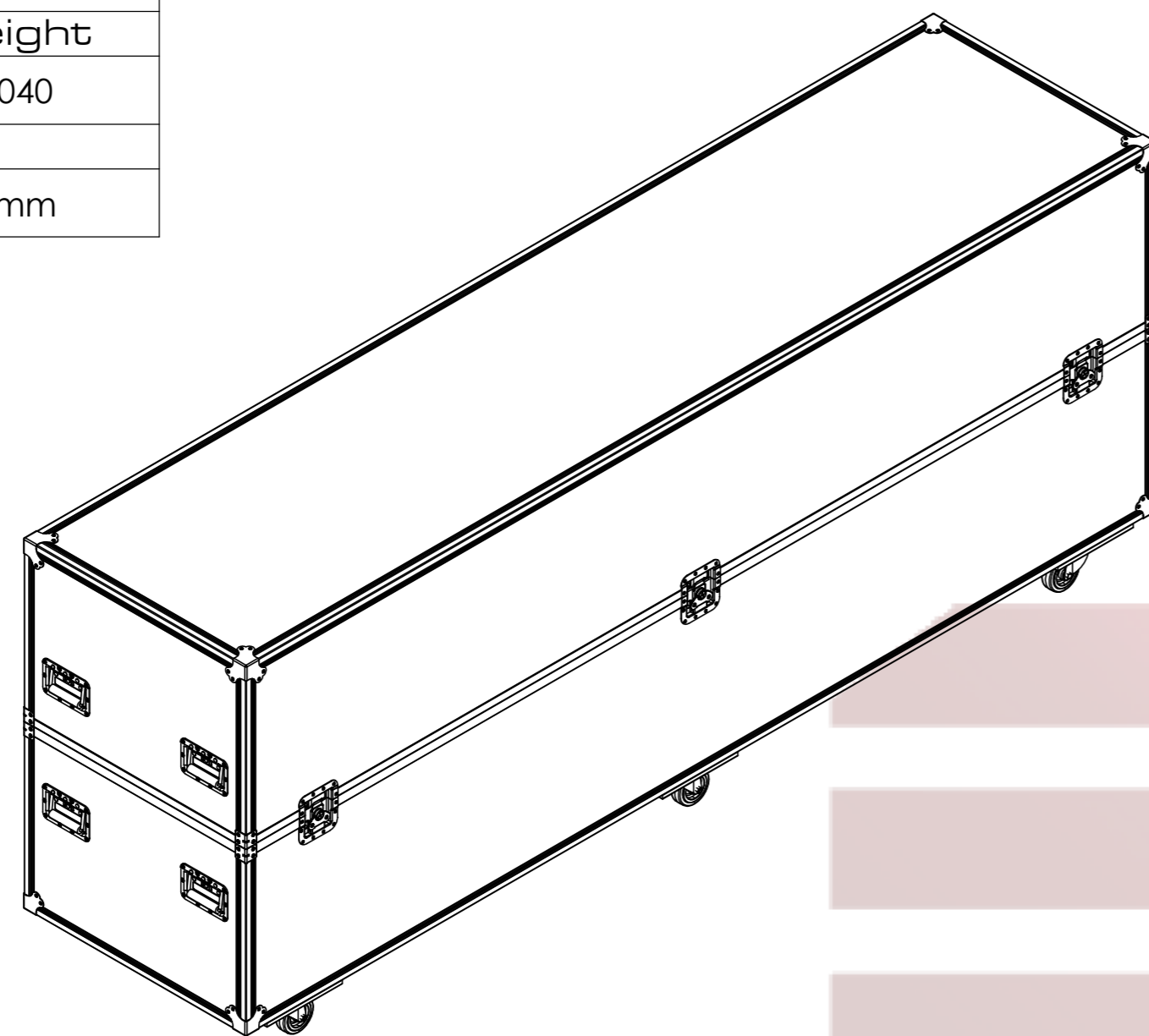

SECTION B-B

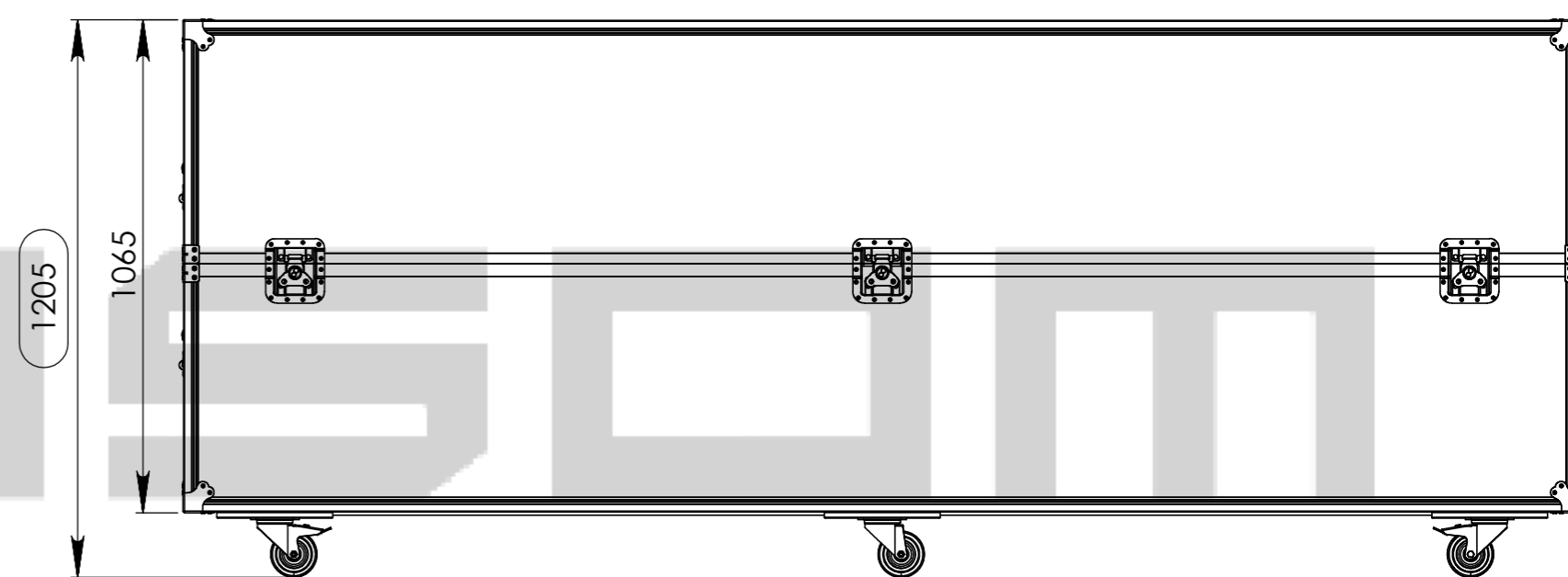
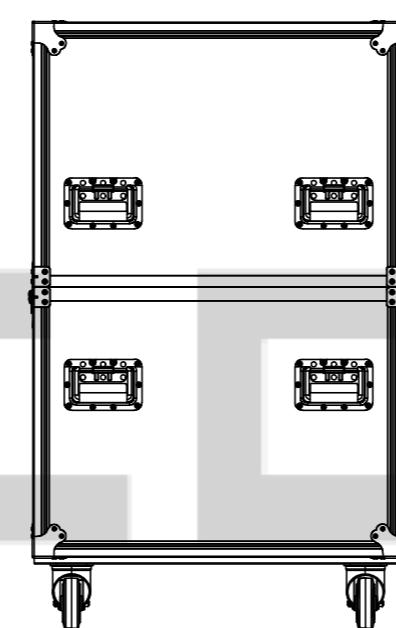
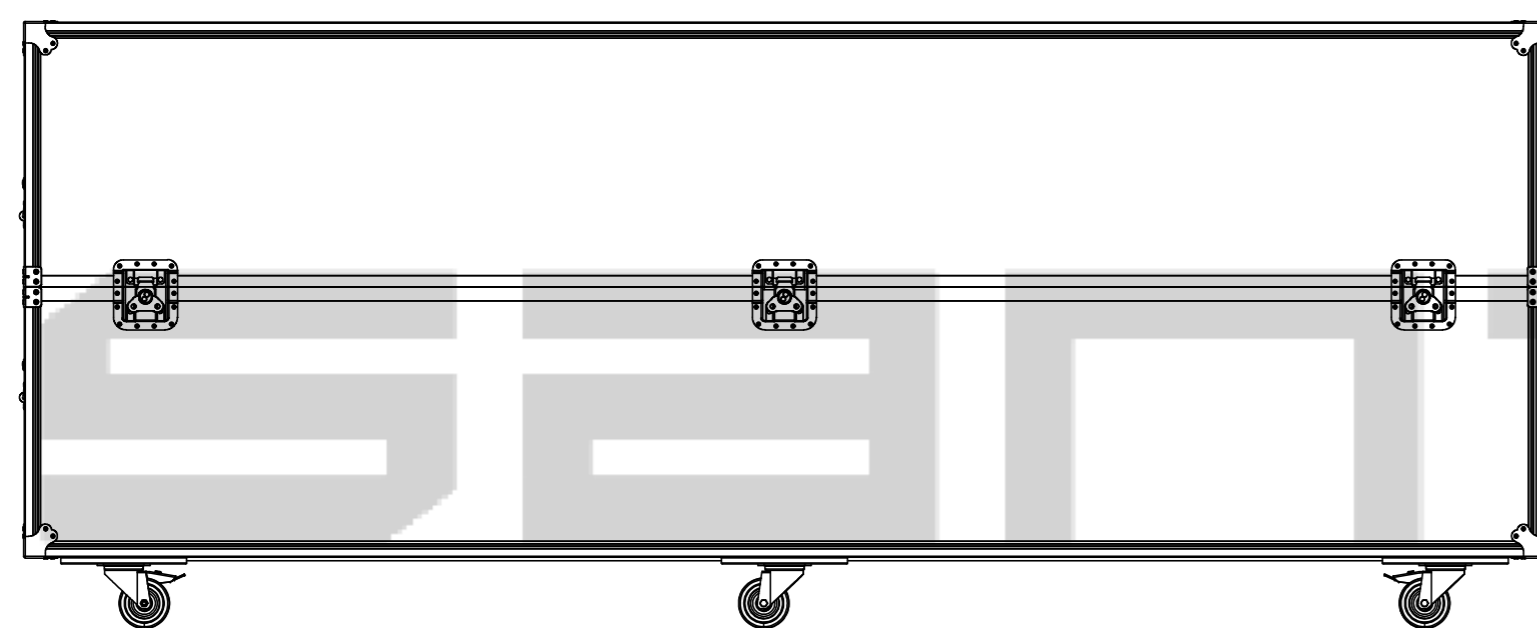

PROFESSIONAL CASES

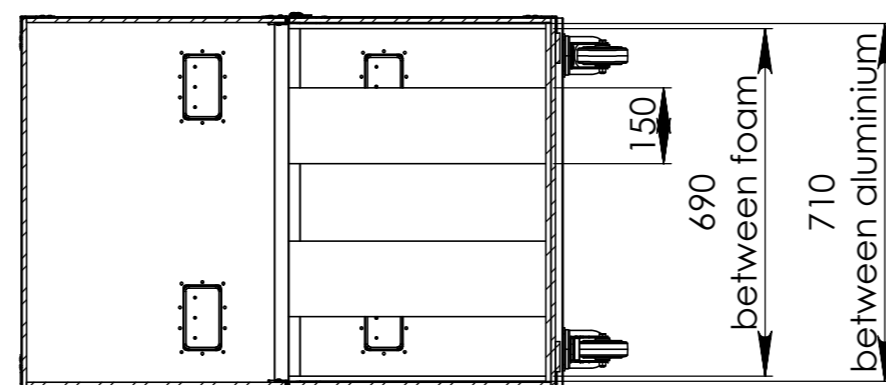

SECTION A-A

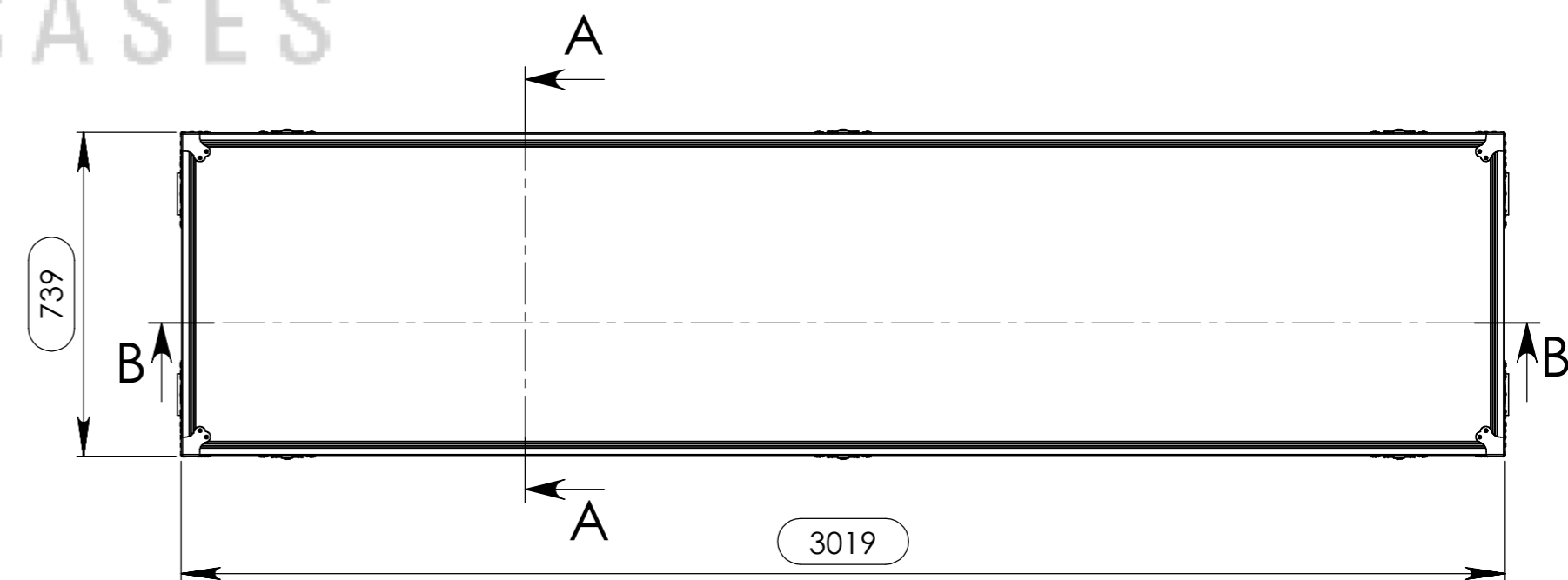

Hardware

Qty	Ref.	Description
8	40403	Large corner bracket f. 35mm case angle
8	4150	Case corner three-leg
6	172531	Large butterfly V3 with 'push-back' function
8	34082	Recessed sprung handle medium model
2	RODA.100T	Swivel castor Ø100mm with brake
4	RODA.100	Swivel castor Ø100 mm

Drawn by	Daniel Lopes	Name	Daniel Lopes	Date	25-02-2014
Reference	2148.S7C	Scale	1:15	general tolerance	±0.8mm
This drawing must not be copied or disclosed without consent of the owner		Scale 1:15 DO NOT SCALE FC, Stand C7V2			