

Interior dimensions

|                |               |        |
|----------------|---------------|--------|
| Width          | Depth         | Height |
| 1850           | 1000          | 840    |
| Weight         | Approx. 79 Kg |        |
| Wall Thickness | 9mm           |        |

| REVISIONS |      |               |            |              |
|-----------|------|---------------|------------|--------------|
| ZONE      | REV. | DESCRIPTION   | DATE       | APPROVED     |
| -         | 0    | Final Drawing | 12/03/2014 | Daniel Lopes |

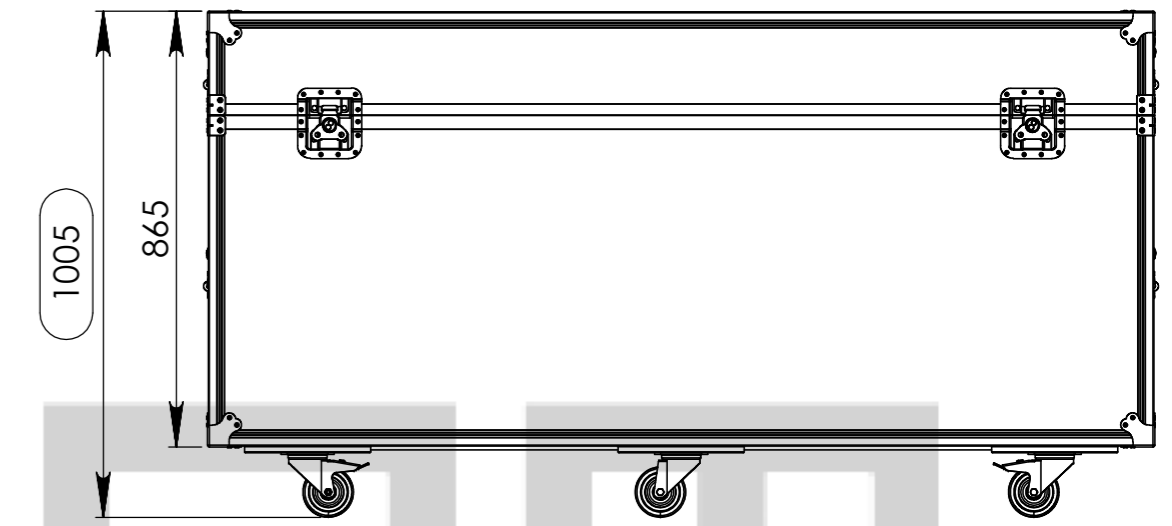
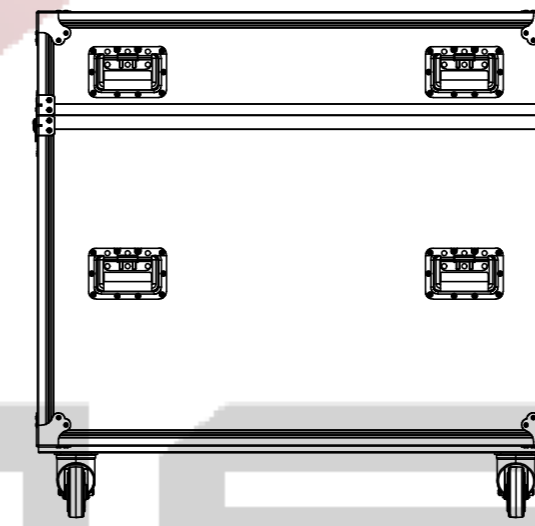
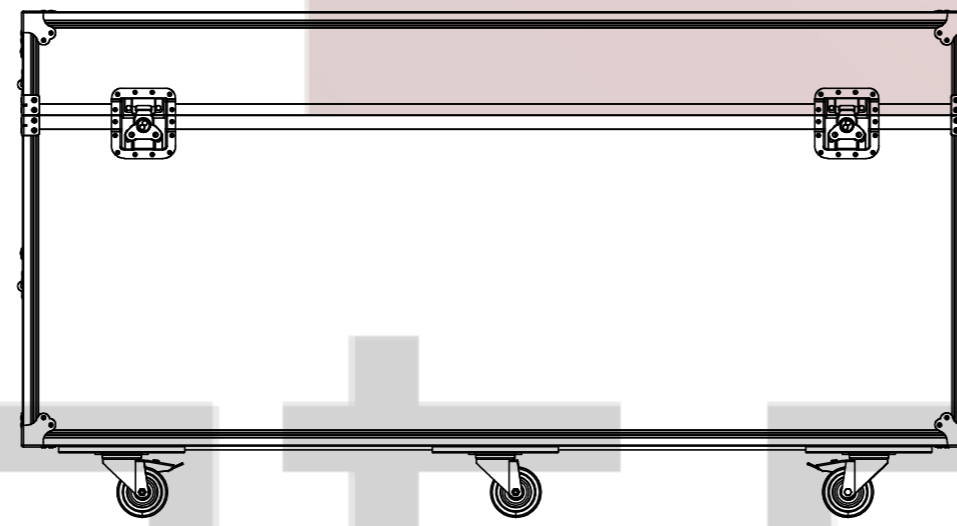
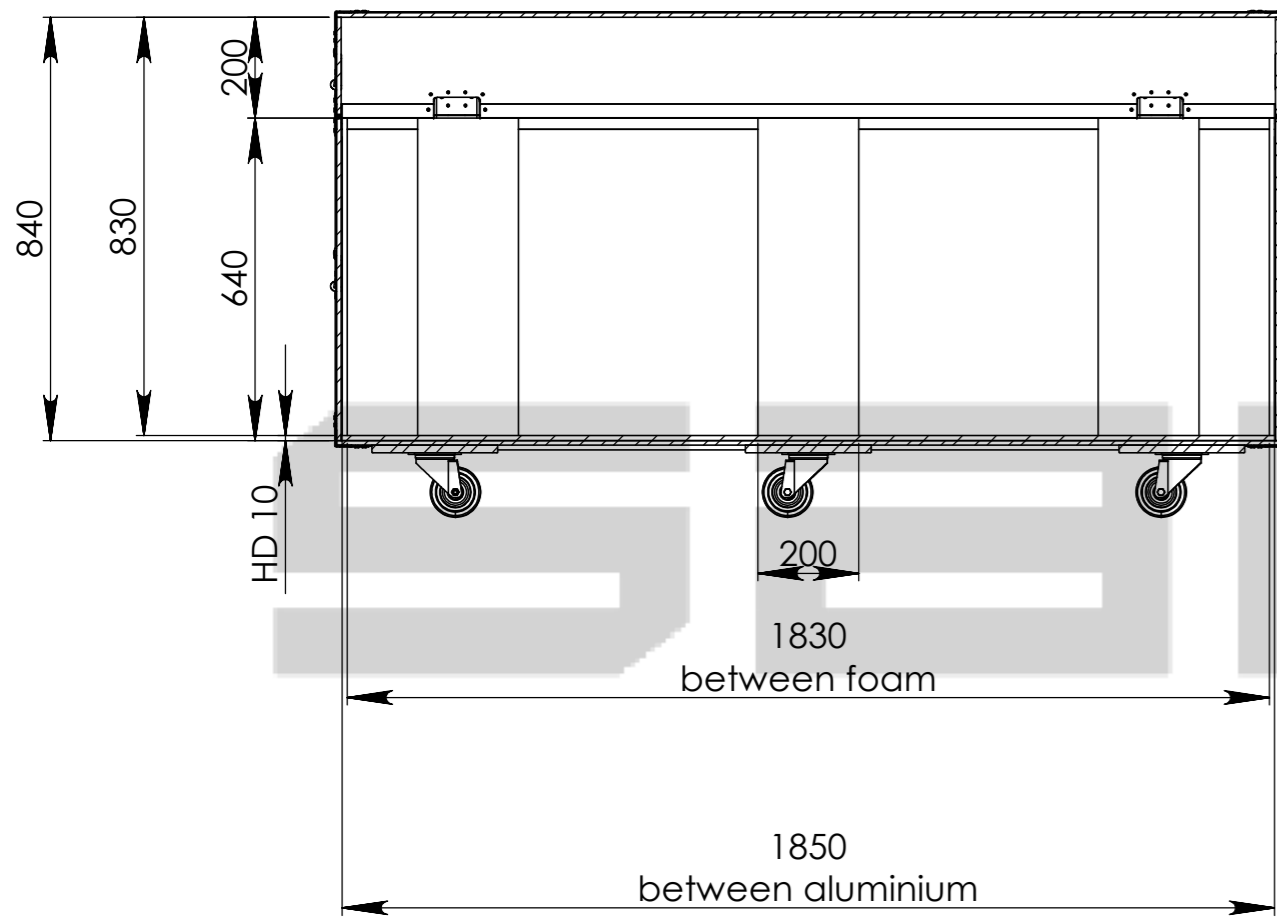
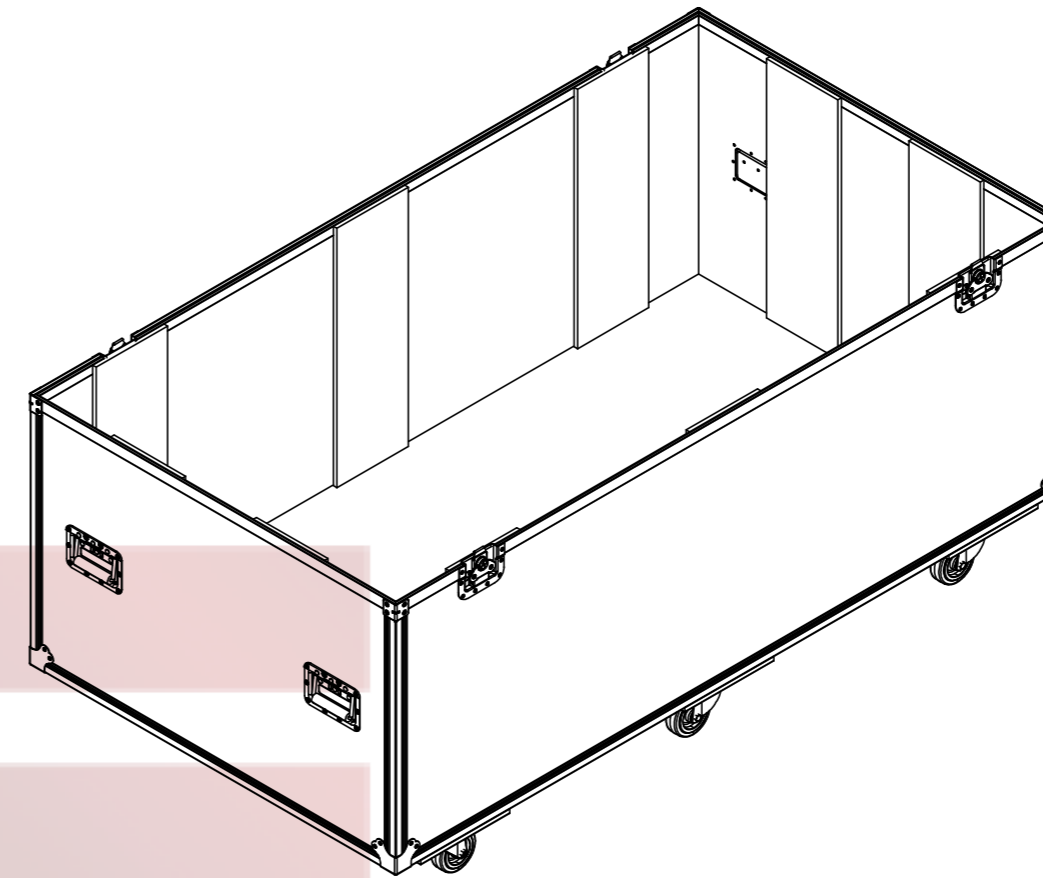
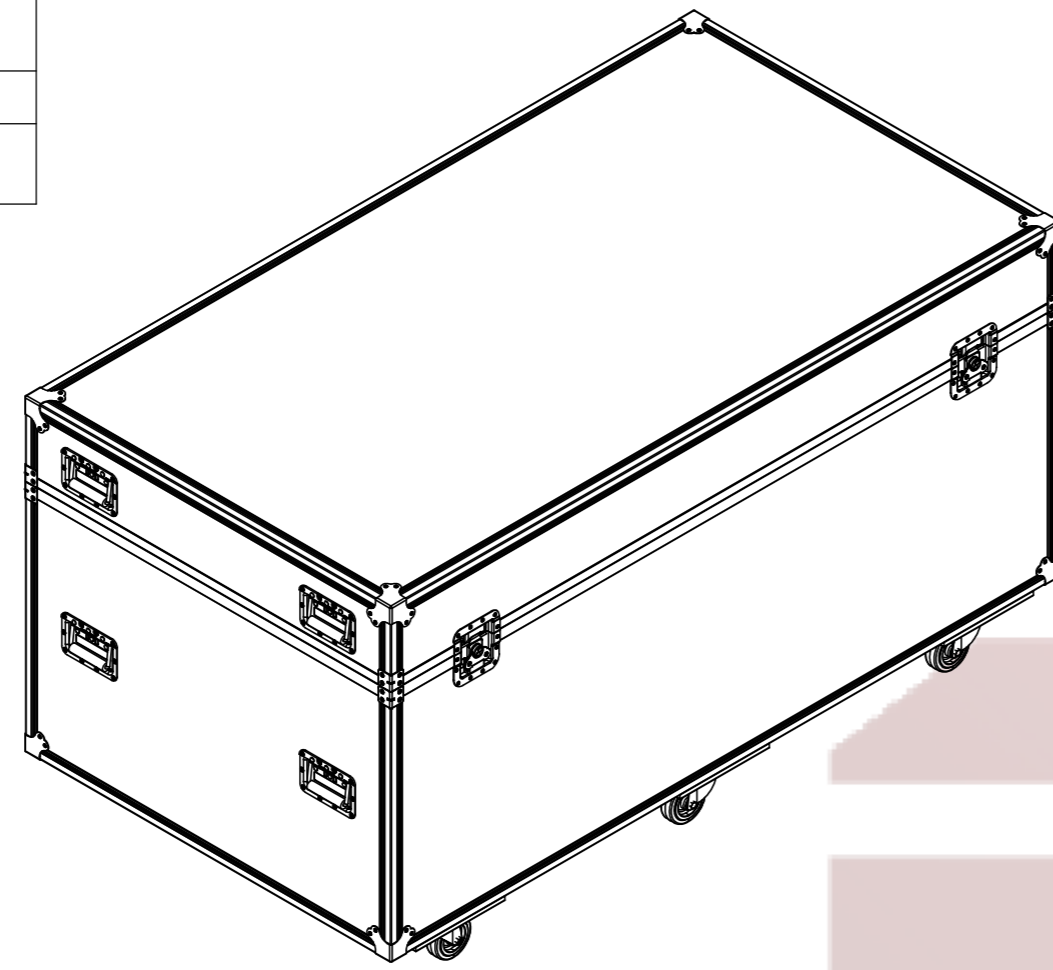

SECTION B-B

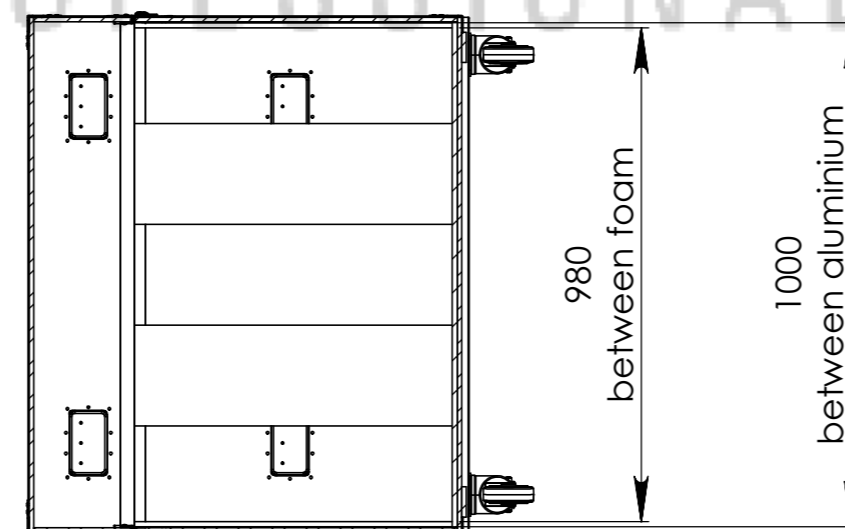

SECTION A-A

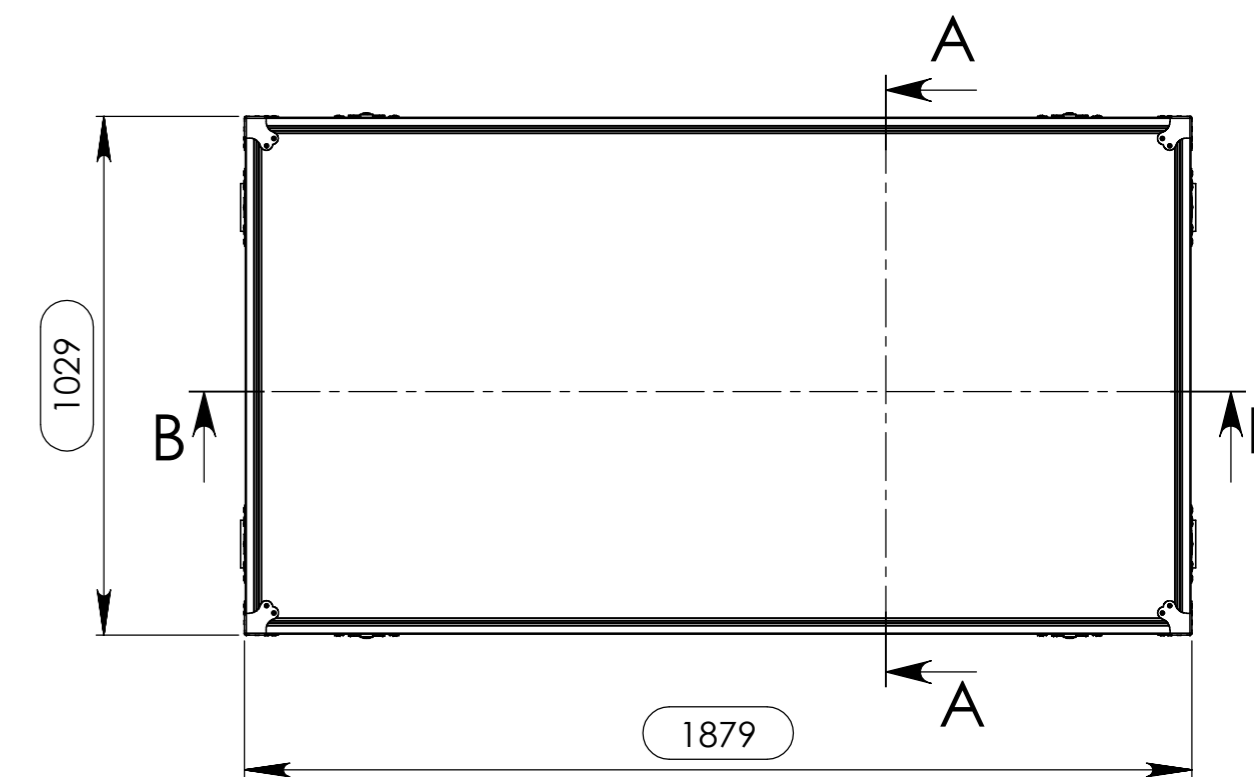

| Hardware |           |  |
|----------|-----------|--|
| Qty      | Ref.      | Description                                  |
| 8        | 40403     | Large corner bracket f. 35mm case angle      |
| 8        | 4150      | Case corner three-leg                        |
| 4        | 172531    | Large butterfly V3 with 'push-back' function |
| 8        | 34082     | Recessed sprung handle medium model          |
| 2        | RODA.100T | Swivel castor Ø100mm with brake              |
| 4        | RODA.100  | Swivel castor Ø100 mm                        |

|              |              |                                     |
|--------------|--------------|-------------------------------------|
| Drawn by     | Name         | Date                                |
| Daniel Lopes | Daniel Lopes | 12-03-2014                          |
| Reference    | 2148.S12A    |                                     |
| Scale        | 1:15         | general tolerance<br>FC, Stand 2AV3 |

This drawing must not be copied or disclosed without consent of the owner