

Interior dimensions		
Width	Depth	Height
2100	880	840
Weight	Approx. 80 Kg	
Wall Thickness	9mm	

REVISIONS				
ZONE	REV.	DESCRIPTION	DATE	APPROVED
-	0	Final Drawing	11/03/2014	Daniel Lopes

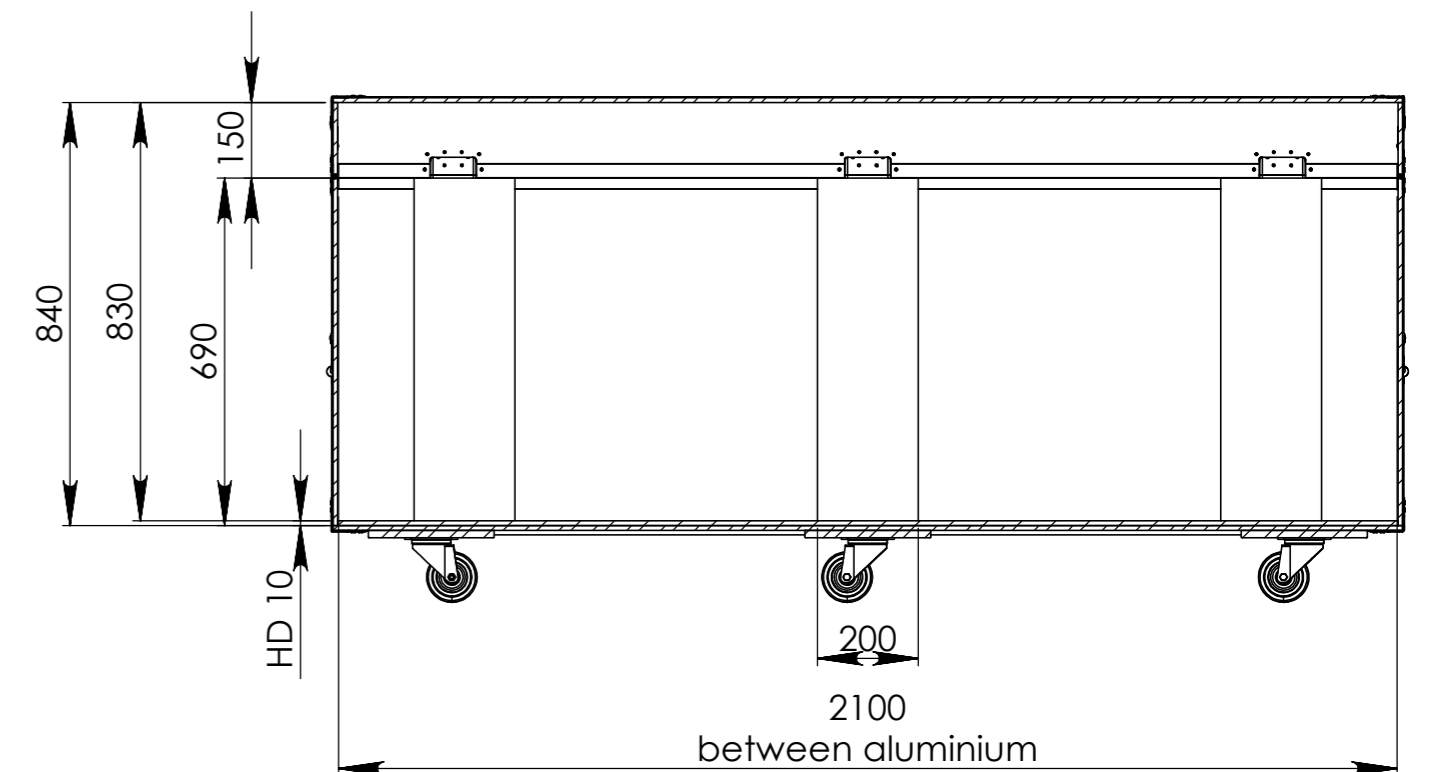

SECTION B-B

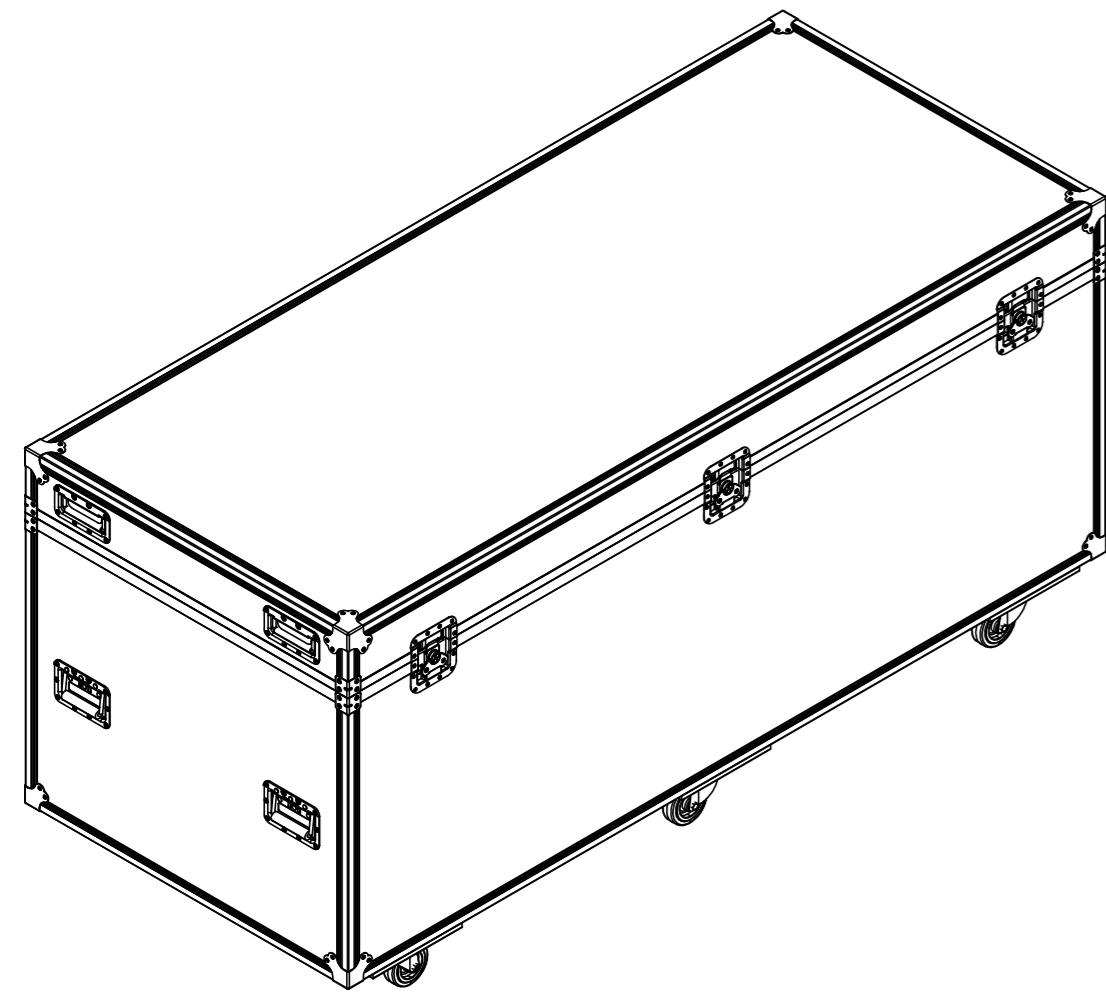
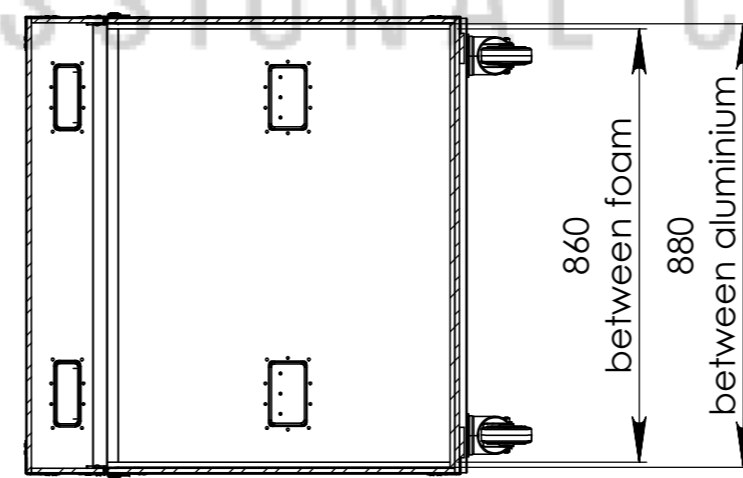
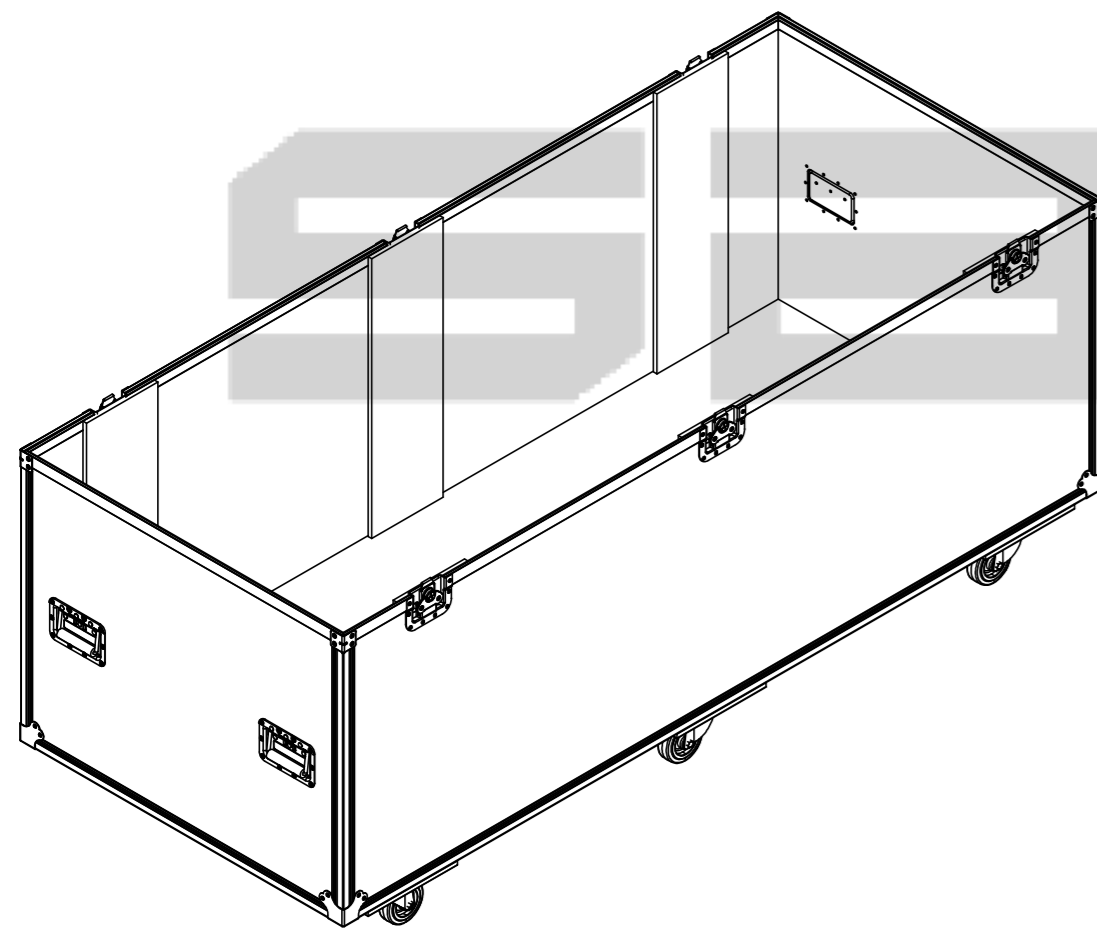
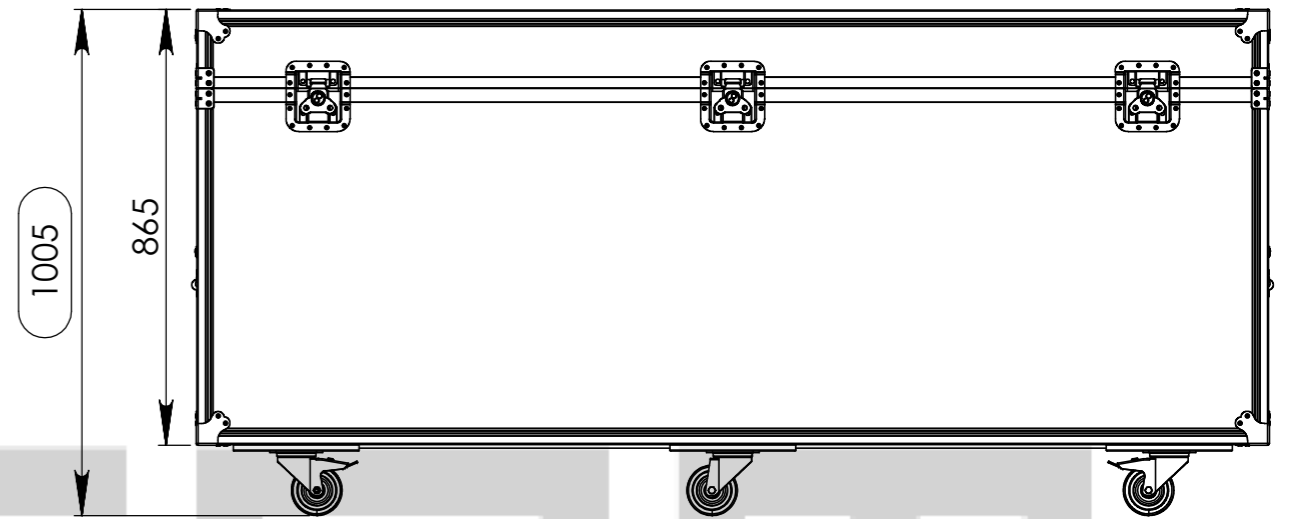
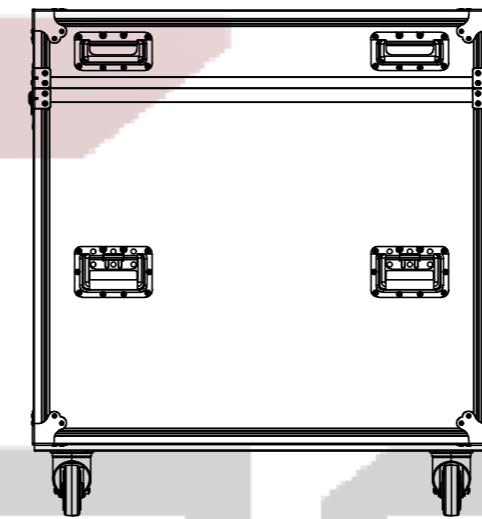
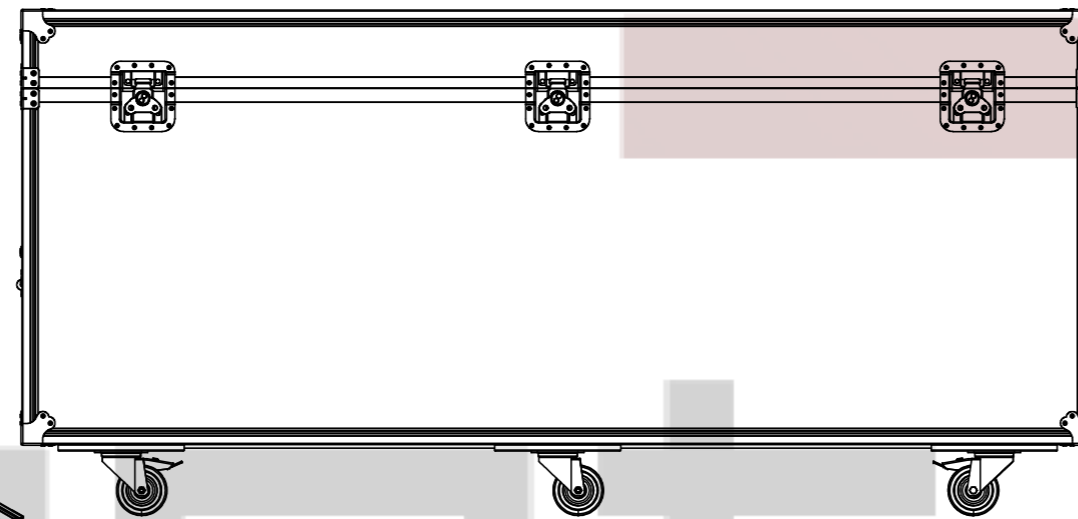

SECTION A-A

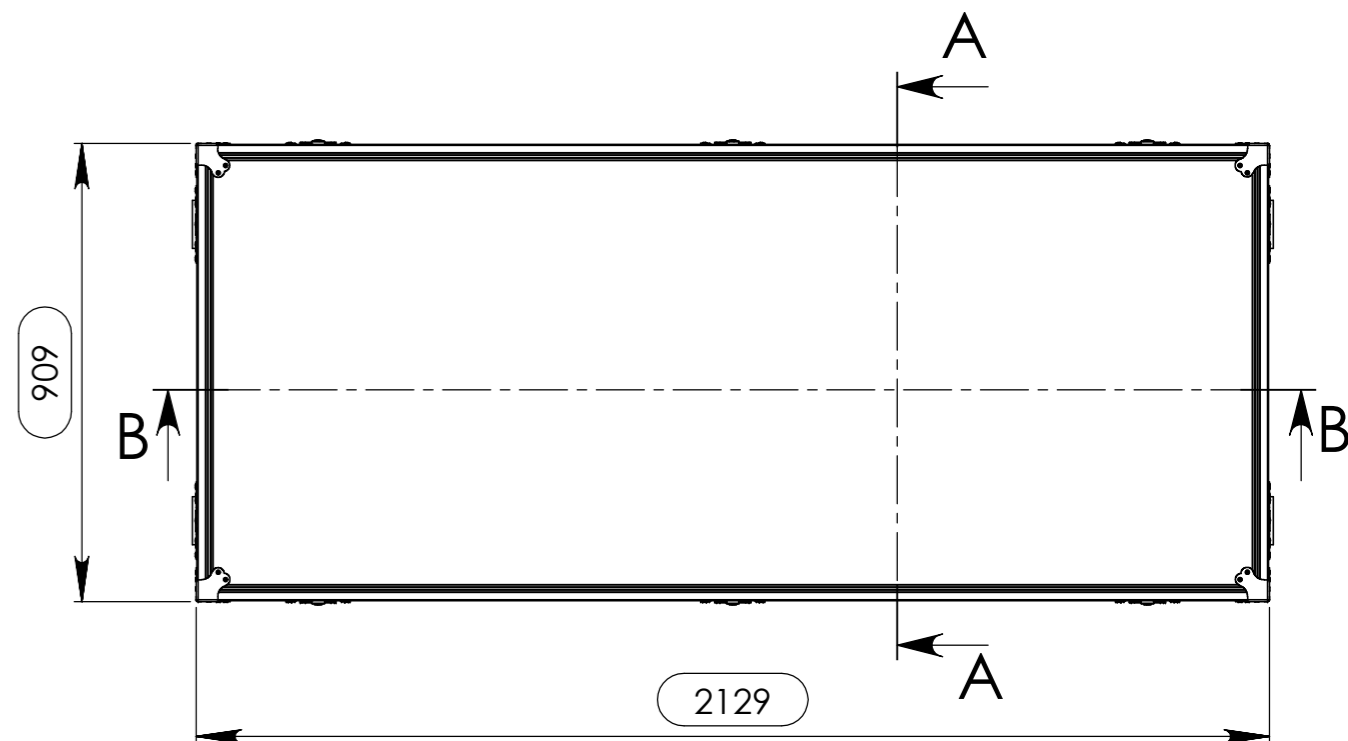

Hardware		
Qty	Ref.	Description
8	40403	Large corner bracket f. 35mm case angle
8	4150	Case corner three-leg
6	172531	Large butterfly V3 with 'push-back' function
4	34082	Recessed sprung handle medium model
2	RODA.100T	Swivel castor Ø100mm with brake
4	RODA.100	Swivel castor Ø100 mm
4	340822	Recessed sprung handle - Small

This drawing must not be copied or disclosed without consent of the owner	Scale 1:15 1st Angle projection	Reference	2148.S1A
		Name	Daniel Lopes
		Date	11-03-2014
		general tolerance	±0.3mm
		FC, Stand 1AV3	