

Interior dimensions

Width	Depth	Height
212	202	295
Weight	Approx. 3 Kg	
Wall Thickness	5mm	

TABELA DE REVISÕES				
ZONE	REV.	DESCRIÇÃO	DATA	Desenhou
-	1	Final Drawing	02/10/2017	Catarina Duque

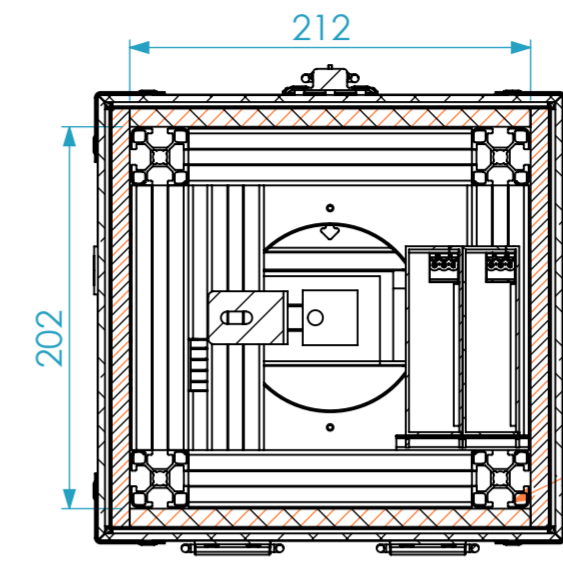
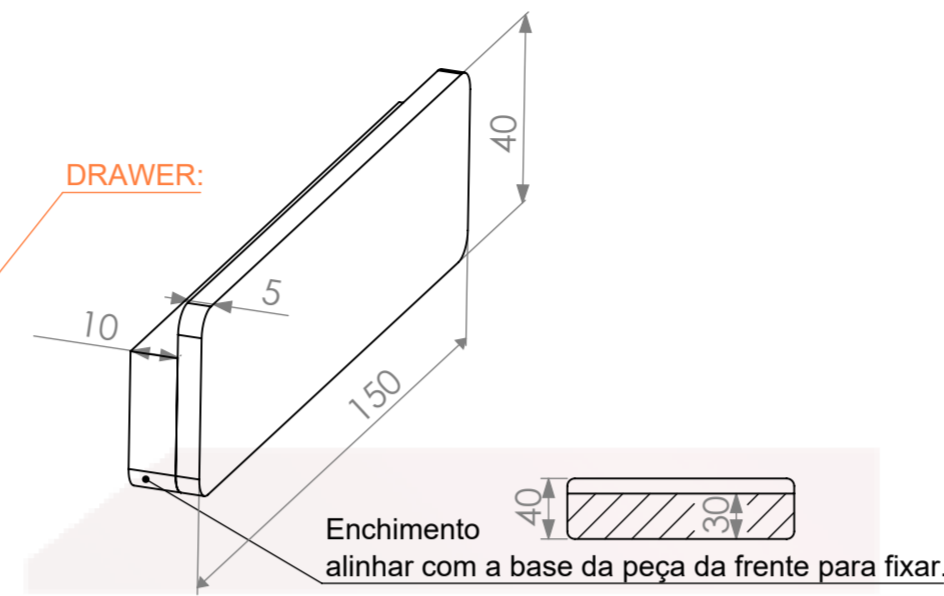
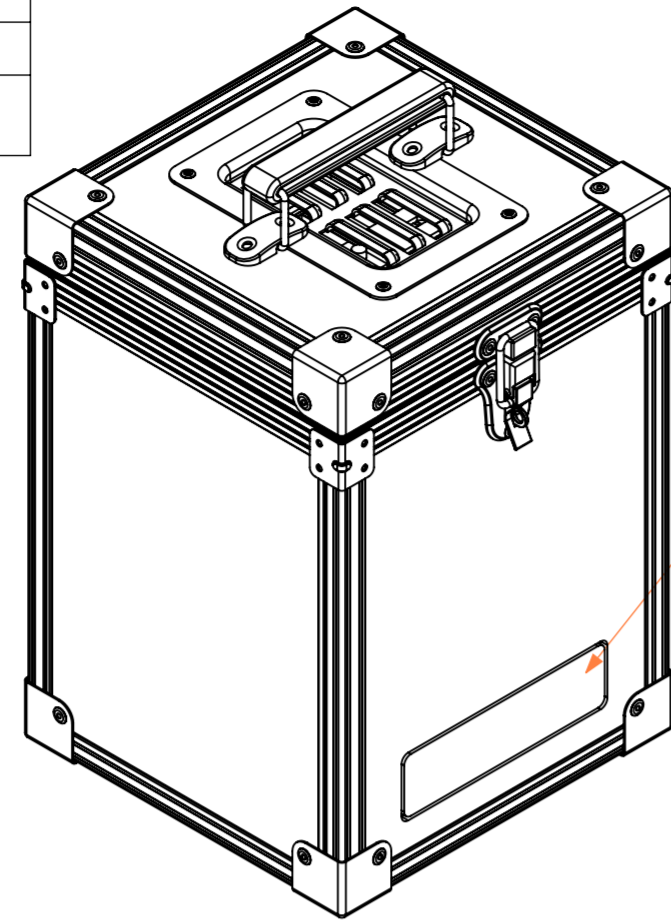

HD foam covering the walls

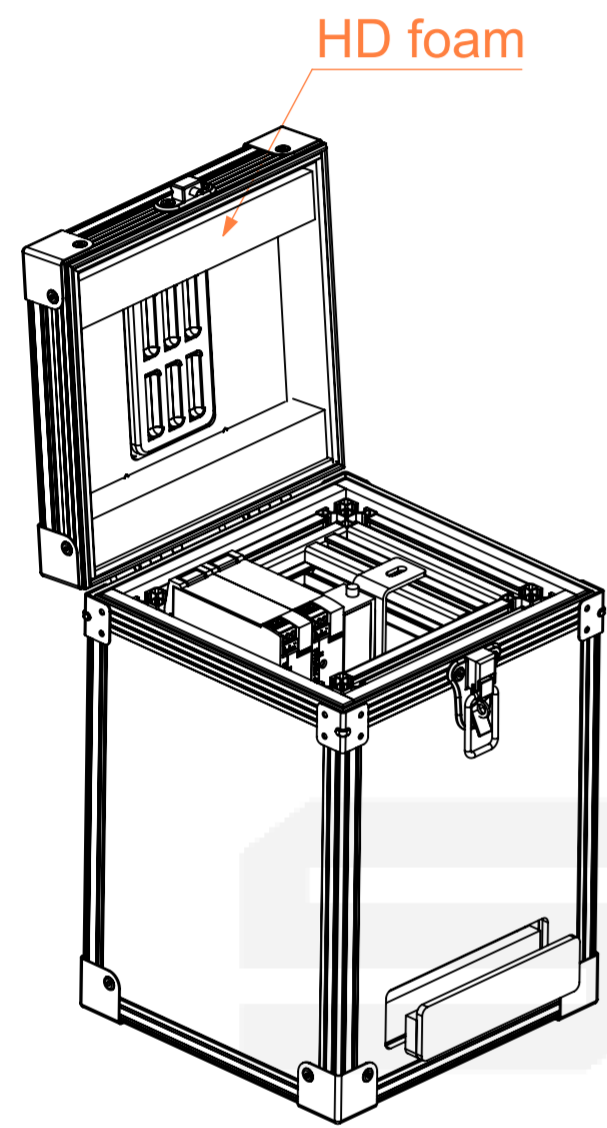

HD foam

Ventilation panel on top lid

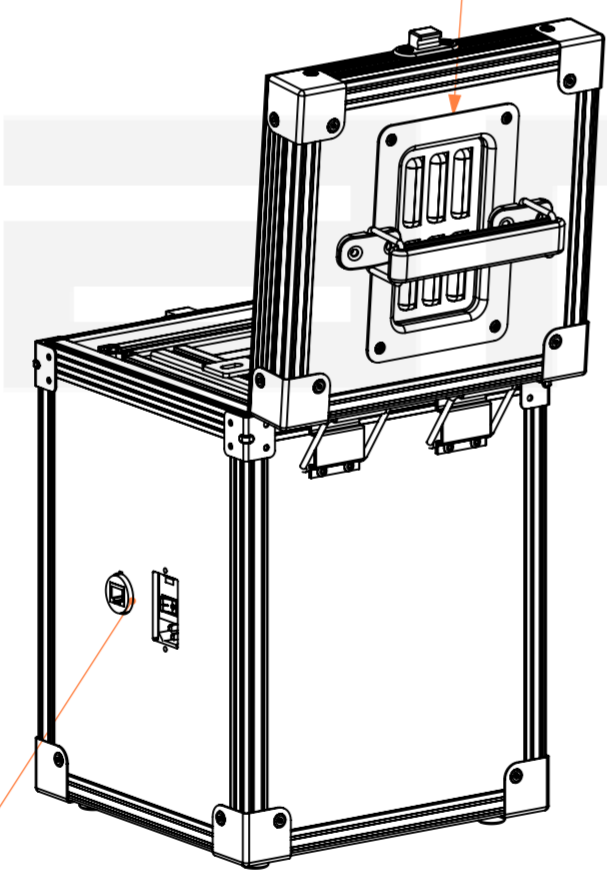

Connections

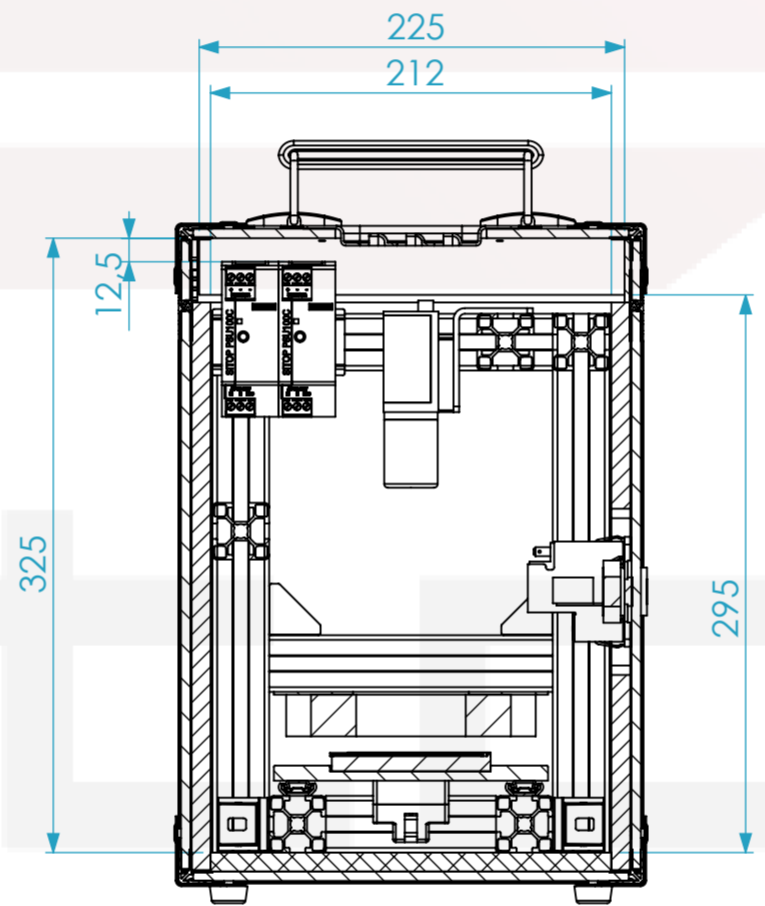

SECTION A-A
SCALE 1 : 4

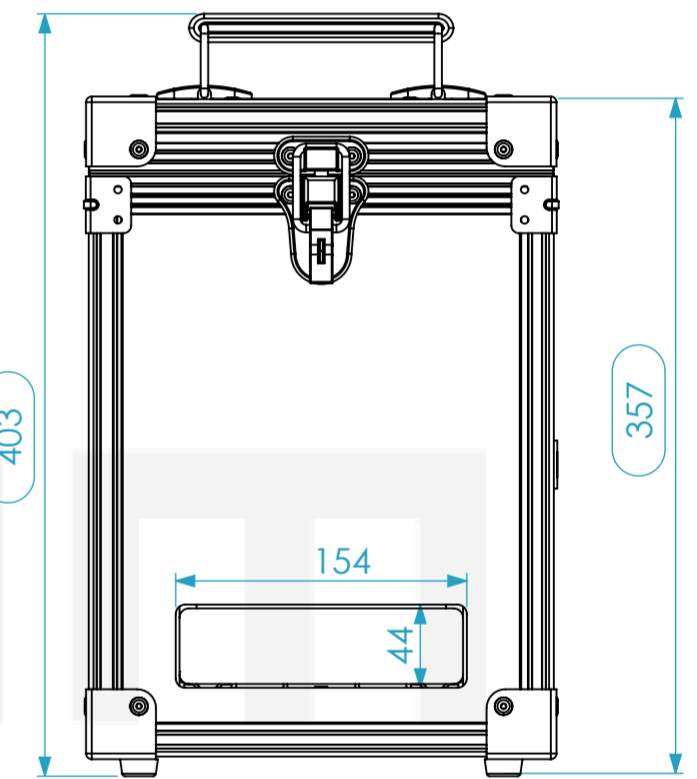
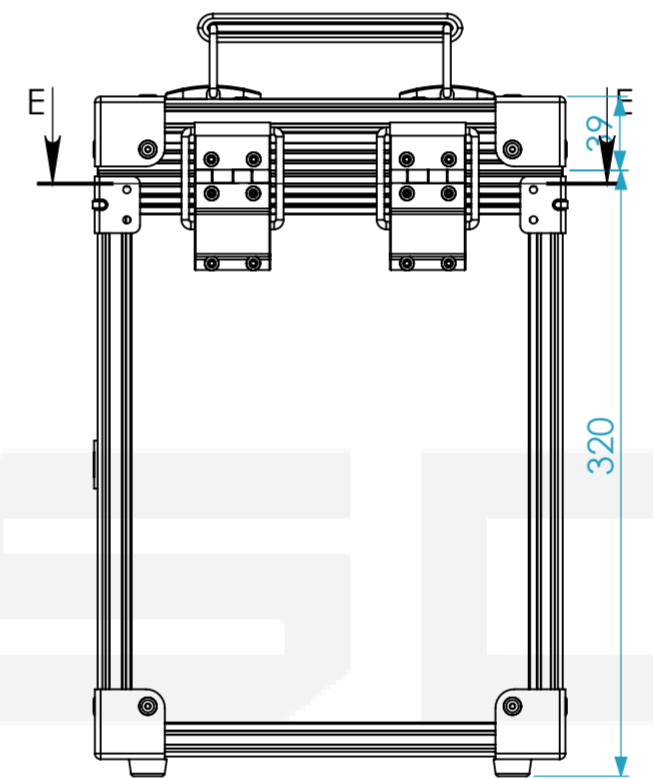

PROFESSIONAL CASES

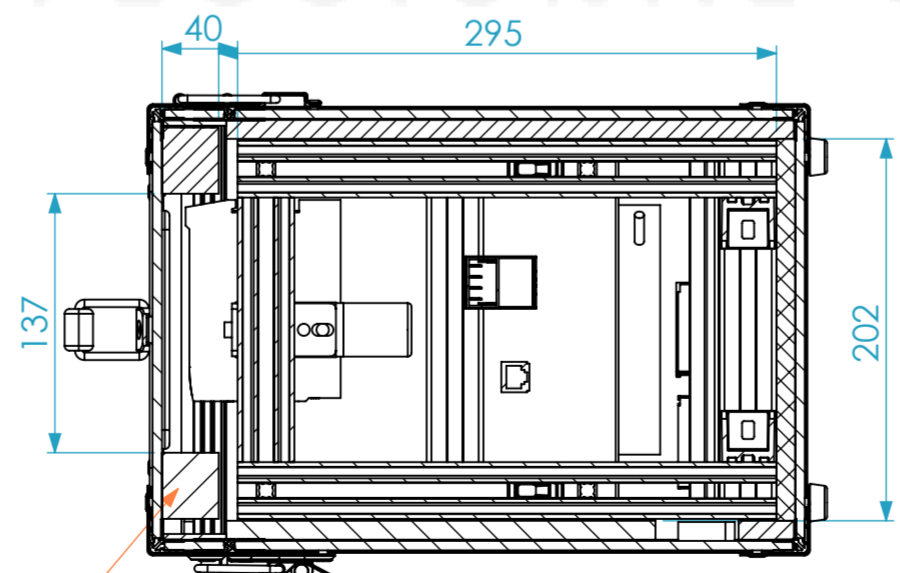

SECTION B-B
SCALE 1 : 4

HD foam

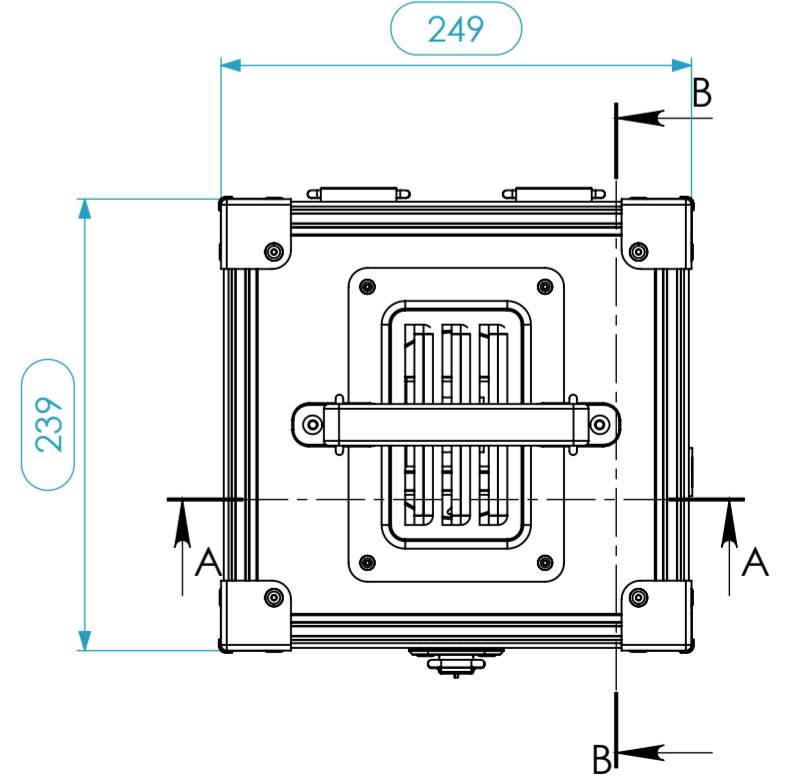
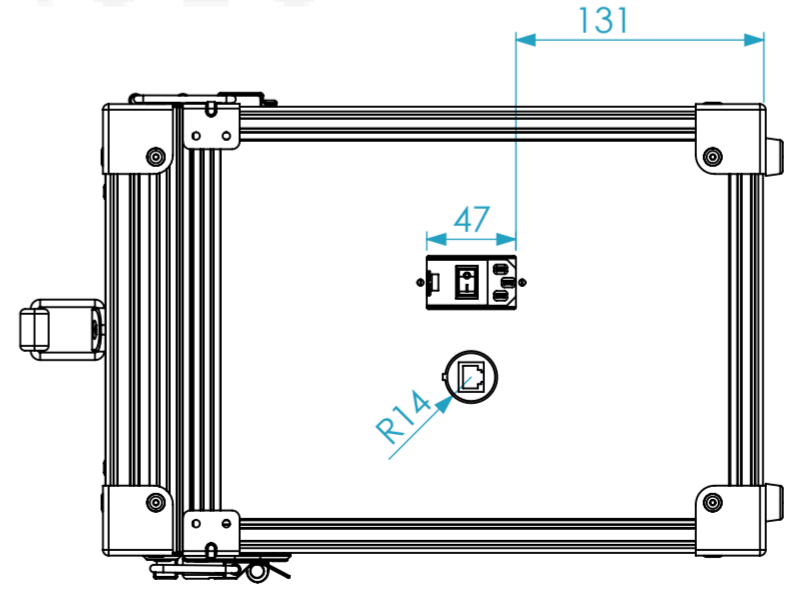

Qty	Hardware Description
8	Square Case Corner
4	Medium corner-brace zinc plated 1,0mm
2	LARGE STRUT HINGE N/P
1	Large padlocking drawbolt
1	Ventilation dish horizontal
1	Leather Case Handle

This drawing must not be copied or disclosed without consent of the owner

Drawn by	CatarinaDuque	Date	04-10-2017
Reference	2093.101A		
Scale	1:5	units in mm	general tolerance 0.8mm
1st Angle projection	FC, SISTEMA ANÁLISE BRESIMAR AUTOMAÇÃO, SA		