

Interior dimensions		
Width	Depth	Height
365	225	480
Weight	Approx. 9 Kg	
Wall Thickness	5mm	

DETAIL C
SCALE 2 : 5

TABELA DE REVISÕES				
ZONE	REV.	DESCRIÇÃO	DATA	Desenhou
-	1	Final Drawing	13/03/2014	Pedro Neves

ABERTURA NA REGUA DA TAMPA FORRADA COM FILTRO ACUSTICO PARA VENTILAÇÃO

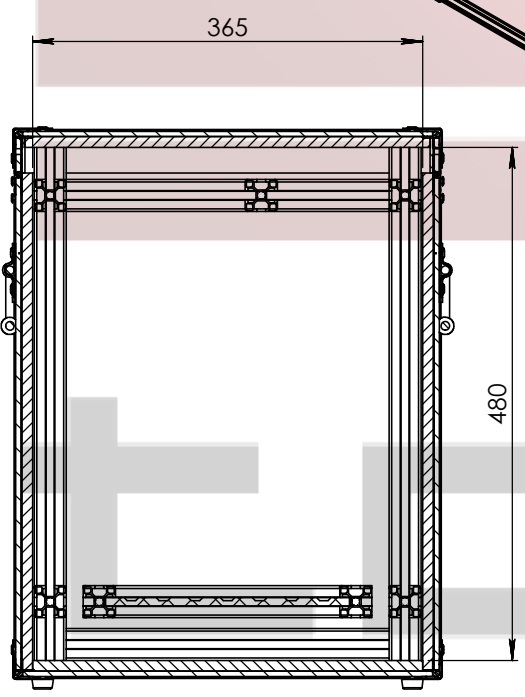
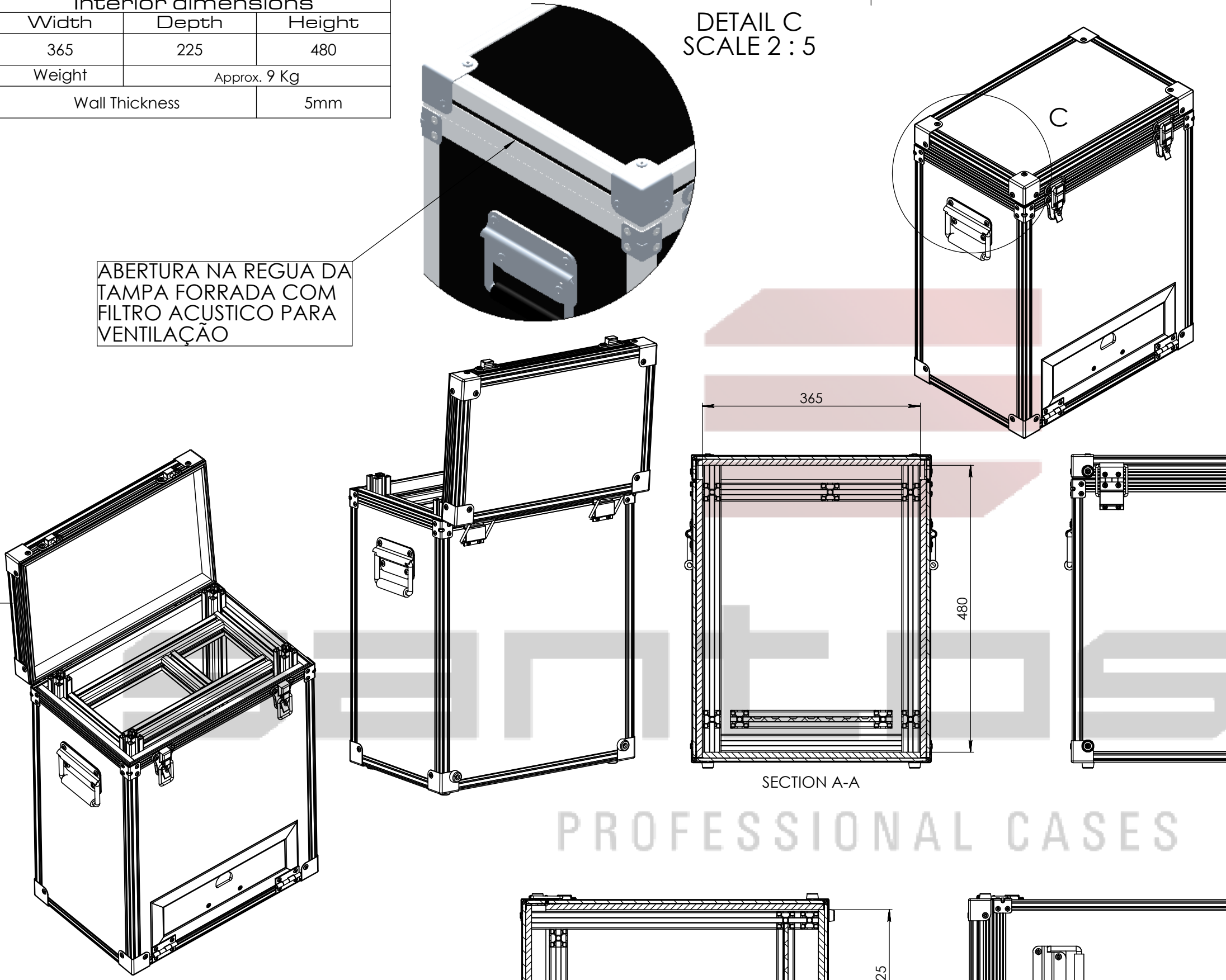

SECTION A-A

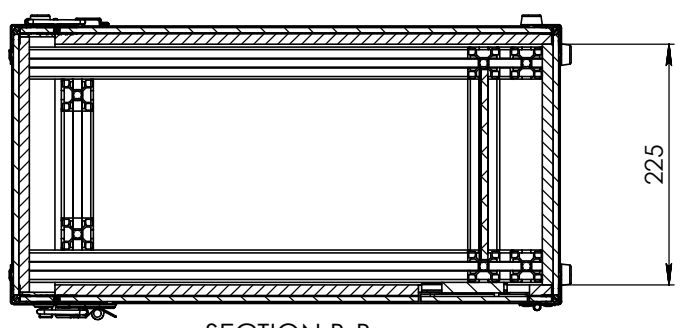
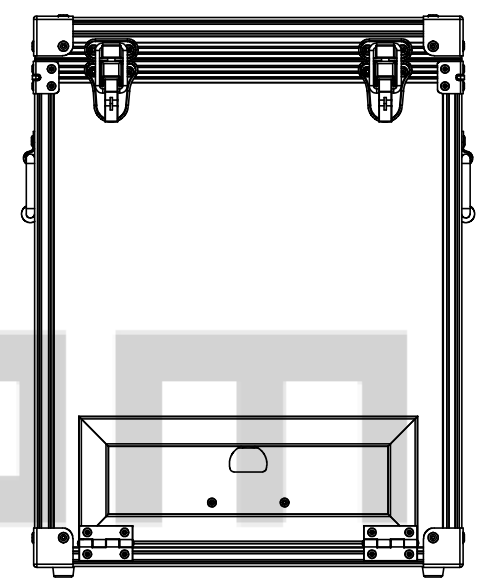
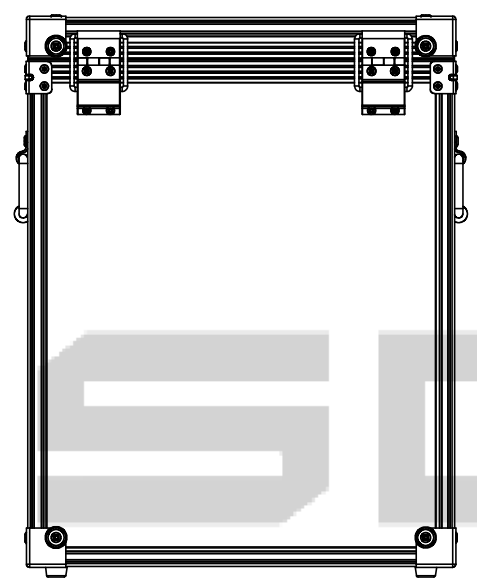

SECTION B-B

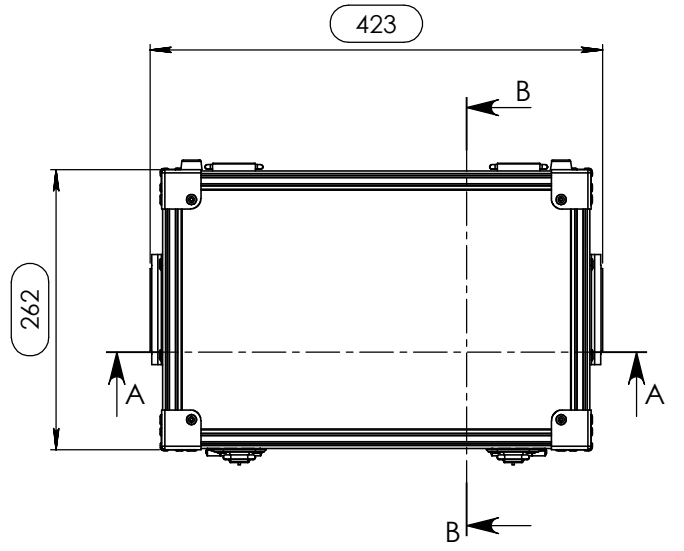
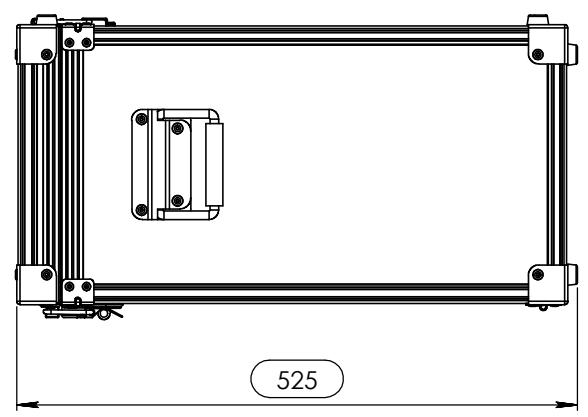

Hardware	
Qty	Description
8	Square Case Corner
4	Medium corner-brace zinc plated 1,0mm
8	Rubber foot 20 x 9 mm, black
2	LARGE STRUT HINGE N/P
2	Large padlocking drawbolt
1	Sliding Latch System - Sliding Latch
2	Hinge small 1,3 mm Steel zinc plated

PROFESSIONAL CASES

Drawn by	Name	Date
pedroneves	pedroneves	13-03-2014
Reference	2093.101	
Scale	1:5	general clearance 0,8mm
FC SISTEMA ANÁLISE BRESIMAR AUTOMAÇÃO, SA		

This drawing must not be copied or disclosed without consent of the owner