

Interior dimensions		
Width	Depth	Height
832	260	220.5
Weight	Approx. 9 Kg	
Wall Thickness		5.5mm

REVISIONS				
ZONE	REV.	DESCRIPTION	DATE	APPROVED
-	0	Final Drawing	06/06/2013	Daniel Lopes

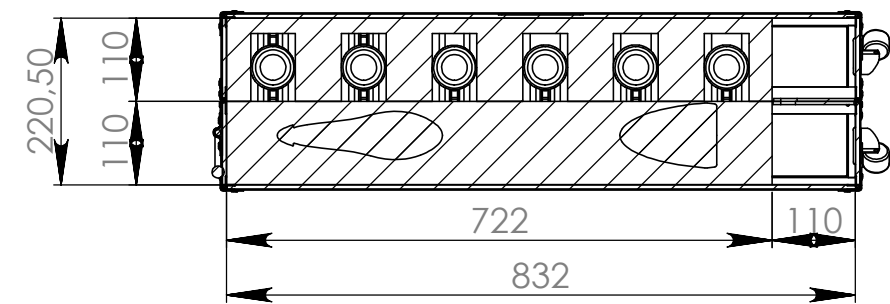

SECTION B-B

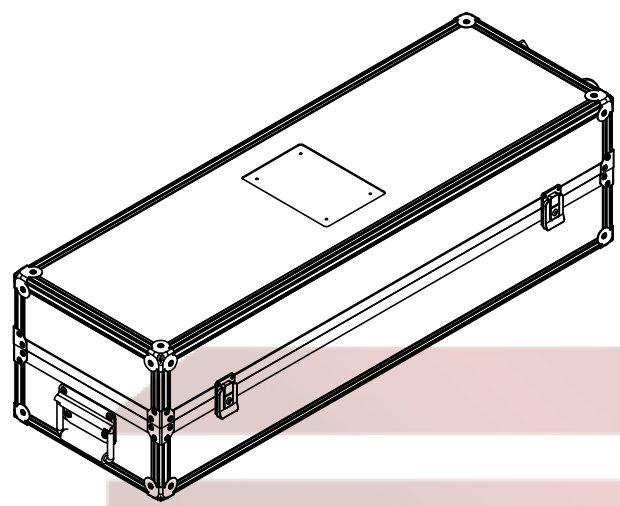
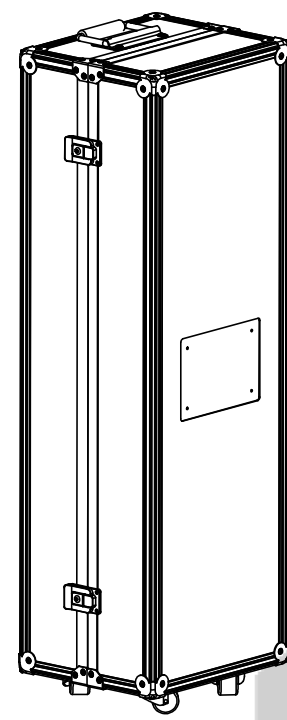
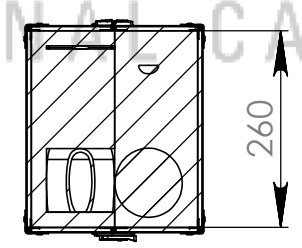
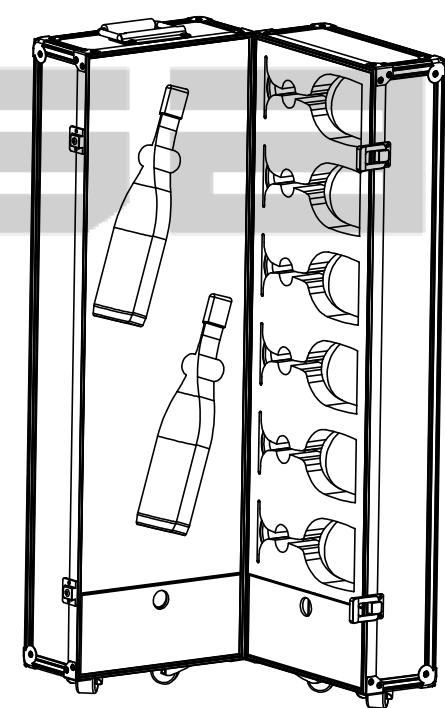
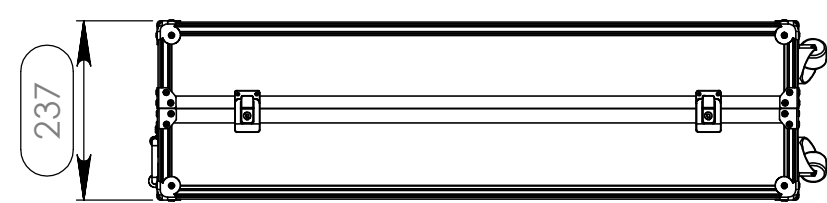
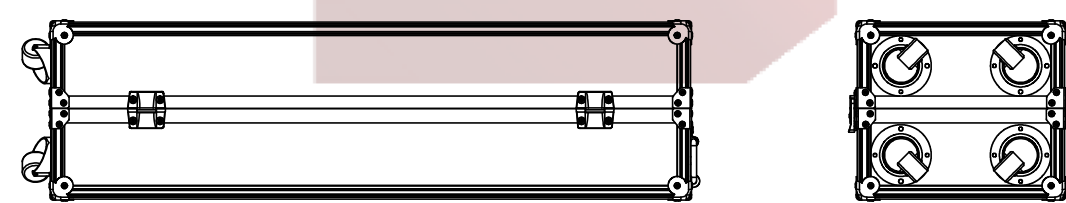

SECTION A-A

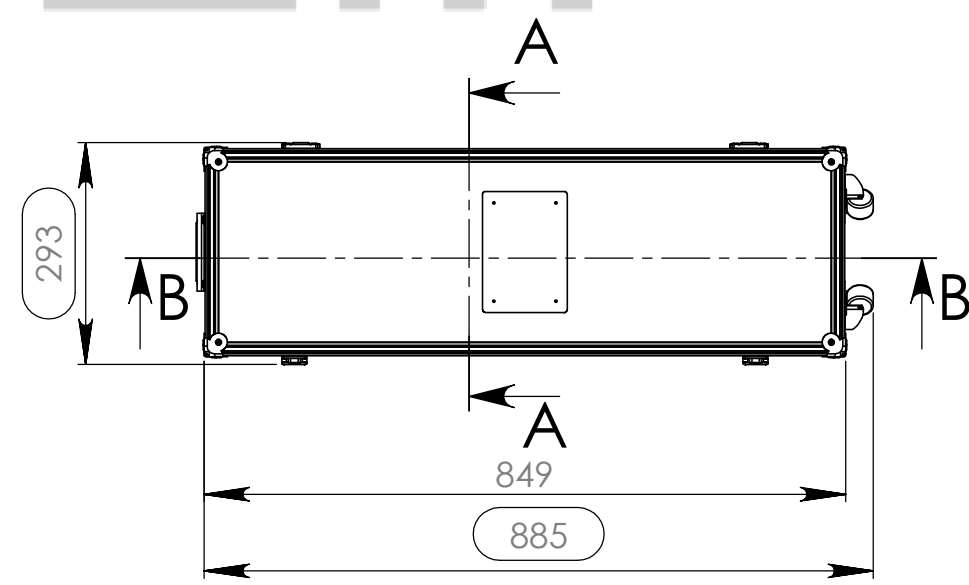

Qty	Ref.	Description
8	4056	Small case corner - 3 leg - 1 mm Steel, chrome plated
8	4046	Small corner brace - suits 6136 casemaker
2	2508	MEDIUM STOP-HINGE
2	1919	SIMPLE BLOCK CATCH.

This drawing must not be copied or disclosed without consent of the owner

Drawn by	Name	Date
DanielLopes	DanielLopes	06-06-2013
Reference	2031.003	
Scale	units in mm	general tolerance
1:10	DO NOT SCALE	0.8mm
BRIEFCASE, 2 GARRAFAS 6 COPOS MOET & CHANDON, RODAS		

