

Interior dimensions		
Width	Depth	Height
830	500	60
Weight	Approx. 7 Kg	
Wall Thickness	7mm	

REVISIONS				
ZONE	REV.	DESCRIPTION	DATE	APPROVED
-	-	Final Drawing	06/03/2013	Daniel Lopes

Foam for equipments

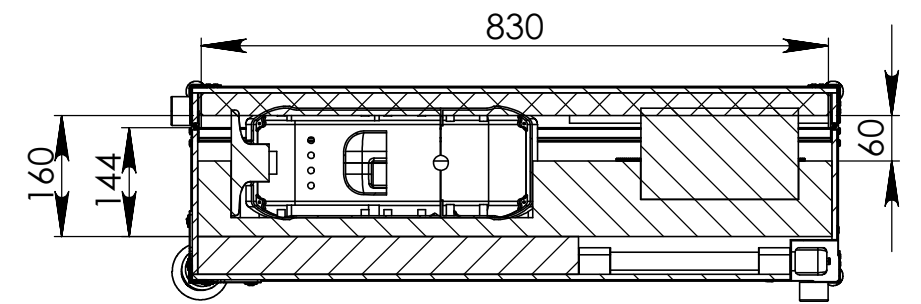
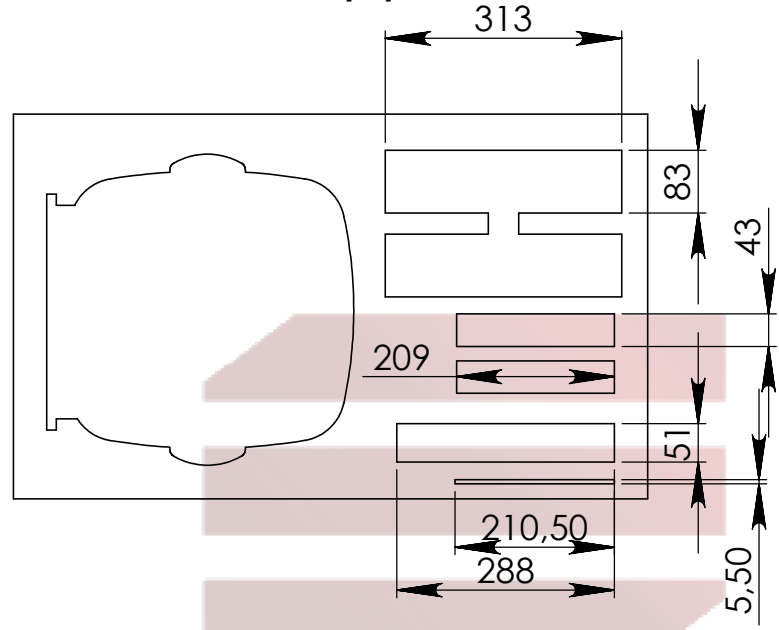

SECTION B-B

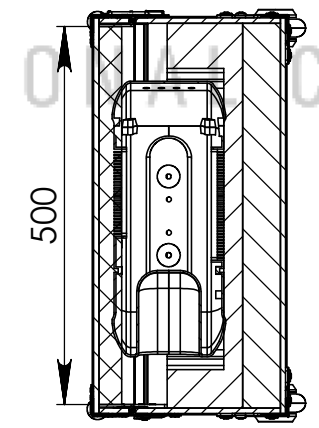
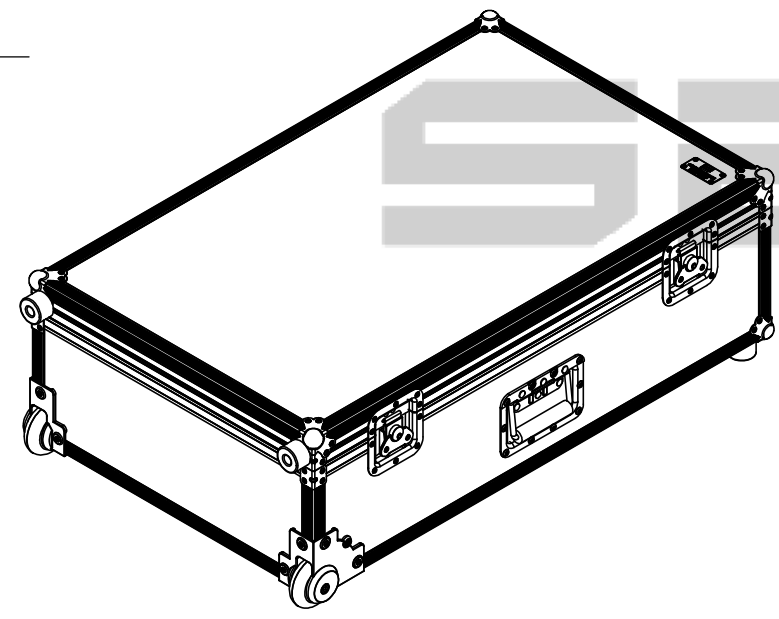
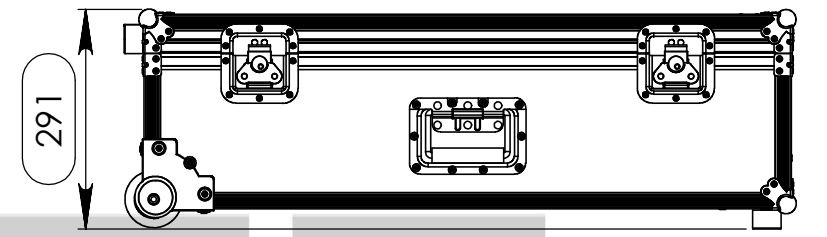
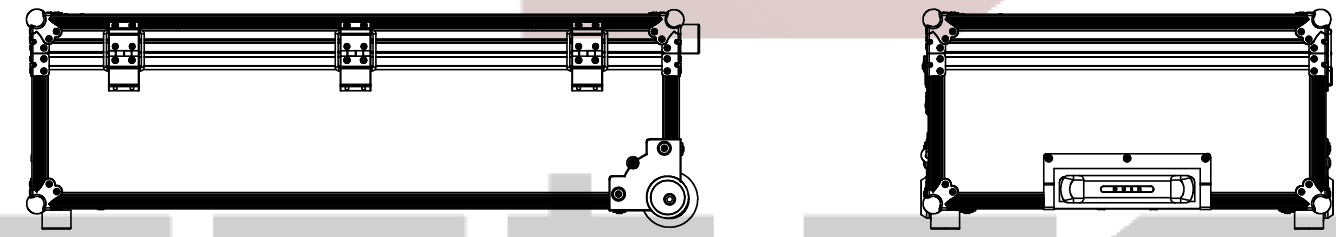

SECTION A-A

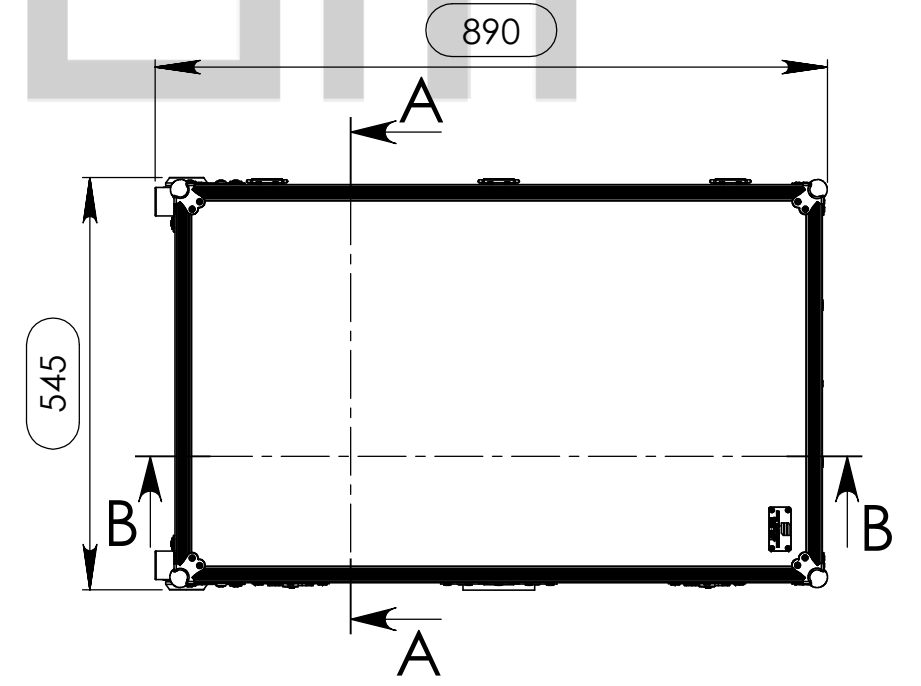

Hardware	
Qty	Description
8	Medium corner-brace zinc plated 1,0mm
4	Rubber foot 38 x 25 mm with steel insert
6	Small ball corner - 3 leg - zinc plated
1	Recessed sprung handle medium model
3	Heavy Duty Strut Hinge, zinc plated
2	Recessed Corner Castor 75mm, Die-Cast Housing
2	Key lockable medium Butterfly special

This drawing must not be copied or disclosed without consent of the owner

Name	Date
Drawn by: DanielLopes	06-03-2014
Reference	1922.021R
Scale	1:10
units in mm	general tolerance 0,8mm
1st Angle projection	Multicase Maquina de Café ICC6, trolley

