

Interior dimensions

Width	Depth	Height
727	660	1575
Weight	Approx. 34 Kg	
Wall Thickness	10mm	

REVISIONS

ZONE	REV.	DESCRIPTION	DATE	APPROVED
-	0	Final Drawing	30/01/2015	Carlos Rodrigues

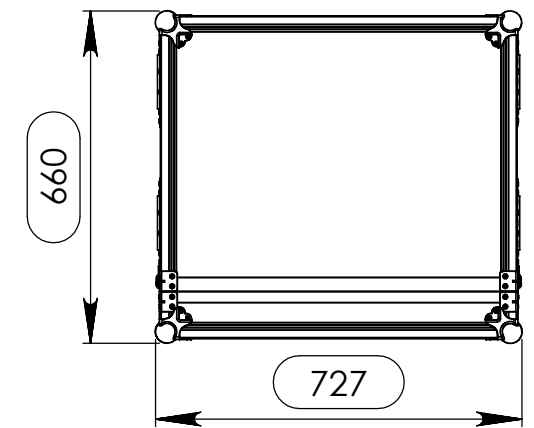
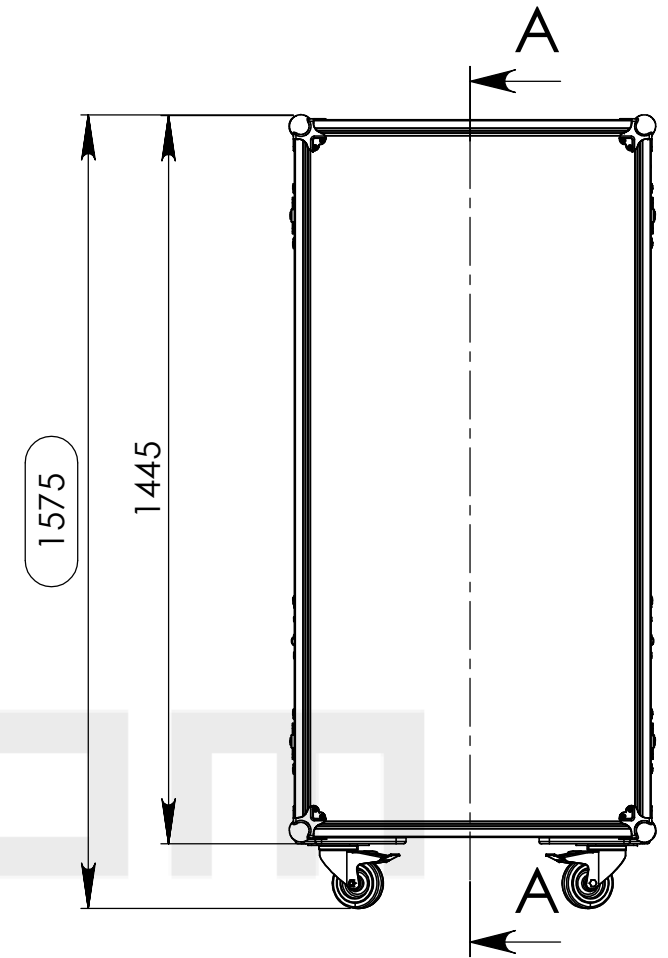
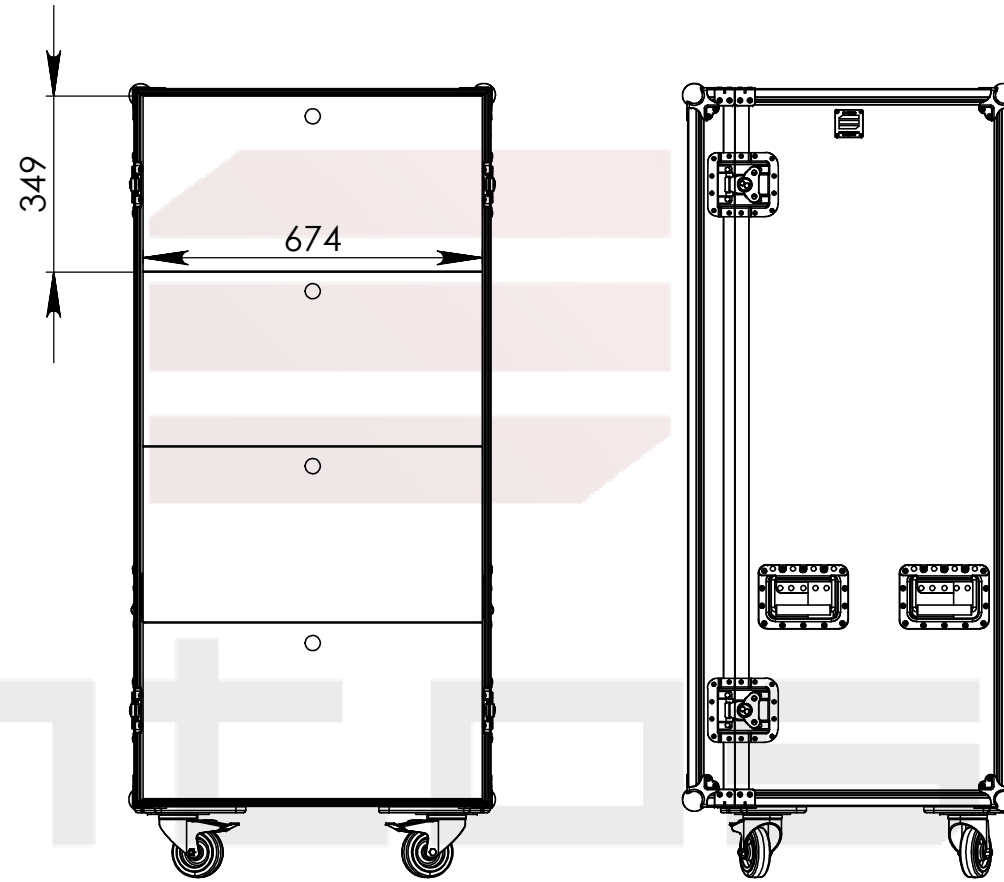
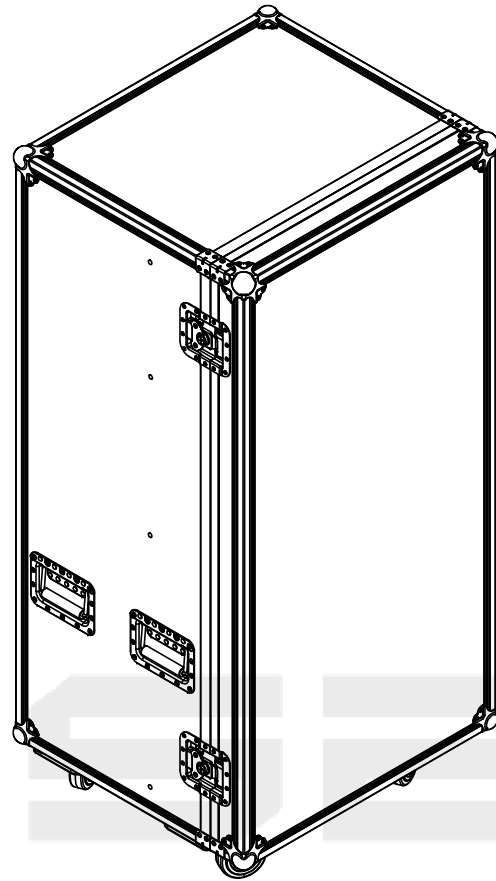

PROFESSIONAL CASES

Hardware

Qty	Ref.	Description
8	410429	Heavy Duty Ball Corner
8	40403	Large corner bracket f. 35mm case angle
4	172531	Large butterfly V3 with 'push-back' function
4	RODAS.1001	Castor plate wood black
2	RODA.100T	Swivel castor Ø100mm with brake
2	RODA.100	Swivel castor Ø100 mm
4	34085	Large, heavy duty, recessed sprung handle

This drawing must not be copied or disclosed without consent of the owner



Scale 1:15

units in mm
DO NOT SCALE
general tolerance 0.8mm

FC, 4 GAVETAS
RODAS CAISSE ENREGISTREUR

